



Take your power with you 

Apollo Battery

User Manual



Please visit our website www.srportables.com to register your product.

Copyright

This user manual's copyright belongs to original manufacturer. Any unit or individual shall not reproduce or partially reproduce the contents of this manual without permission, and shall not convert or distribute in any form or means. Manufacturer reserves the copyright, and owns the power of interpretation. All information may be changed or updated without notice, please understand.

Preface

Overview

This manual is aimed at electricians, specialists with professional qualifications and end users. It mainly introduces the assembly, installation, electrical connection, debugging, maintenance and troubleshooting of the products. Before installing and using battery, please read this manual carefully, understand the safety information and be familiar with the functions and characteristics of hybrid battery.

Target Groups

This manual is applicable to the electrical installers with professional qualifications and end-users.

Contents

1. Safety Instructions	3
1.1 Safety Notes	3
1.2 Important Safety Matters	4
1.3 Environmental Conditions	6
1.4 Symbol on the Battery Label	6
1.5 Symbol on the Packing Box	7
2. Battery Introduction	8
2.1 Appearance Introduction	8
2.2 Packing List	10
3. Installation	12
3.1 Location Requirements	12
3.2 Mounting.....	12
3.2.1 Install the Base.....	12
3.2.2 Install the Module.....	13
4. Electrical Connection	16
4.1 Cables Connection	16
4.2 Battery Power Connector Assembly Procedures.....	17
4.3 Communication Cable Connection.....	19
5. System Start and Stop	20
5.1 Start System.....	20
5.2 Stop System.....	21
5.3 LED indication.....	22
6. Troubleshooting	23
6.1 Maintenance.....	23
6.2 Maintenance of electrical components.....	23
6.3 Battery Maintenance	24
7. Technical Parameters	25

1 Safety Instructions





1.1 Safety Notes









Before installation, please read this manual and warning labels on battery carefully and follow the instructions in this manual strictly.







1.2 Important Safety Matters

SAVE THESE IMPORTANT SAFETY INSTRUCTIONS.





Apollo Battery installation and maintenance instructions must have high voltage electrical knowledge. The Company assumes no liability for injury or property damage due to repairs attempted by unqualified individuals or a failure to properly follow these instructions. These warnings and cautions must be followed when using our product.

 Warning	<p>Read this entire document before installing or using Apollo Battery. Failure to do so or to follow any of the instructions or warnings in this document can result in electrical shock, serious injury, or death, or can damage Apollo Battery, potentially rendering it inoperable.</p>
 Warning	<p>A battery can present a risk of electrical shock, fire, or explosion from vented gases. Observe proper precautions.</p>
 Warning	<p>Apollo Battery installation must be carried out only by Installers, who have been trained in dealing with high voltage electricity.</p>
 Warning	<p>The product is heavy and challenging to lift.</p>





 Warning	Use Apollo Battery only as directed.
 Warning	Do not use Apollo Battery if it is defective, appears cracked, broken, or otherwise damaged, or fails to operate.
 Warning	Do not attempt to open, disassemble, repair, tamper with, or modify Apollo Battery. Apollo Battery is not user serviceable. LFP Cells in Apollo Battery are not replaceable. Contact the Apollo Authorized Reseller who sold the Apollo Battery for any repairs.
 Warning	Do not connect Apollo Battery to alternating current carrying conductors. Apollo storage system including battery and battery must be wired to either a battery or a DC combiner panel that is then wired to an inverter. No other wiring configuration may be used.
 Warning	Apollo Battery contains components, such as switches and relays, that can produce arcs or sparks.
 Warning	To protect Apollo Battery and its components from damage when transporting, handle with care. Do not impact, pull, drag, or step on Apollo Battery. Do not subject Apollo Battery to any strong force. To prevent damage, leave Apollo Battery in its shipping packaging until it is ready to be installed.
 Warning	Do not insert foreign objects into any part of Apollo Battery.
 Warning	Do not expose Apollo Battery or its components to direct flame.





 Warning	Do not install Apollo Battery near heating equipment.
 Warning	Do not immerse Apollo Battery or its components in water or other fluids.
 Warning	Do not use cleaning solvents to clean Apollo Battery, or expose Apollo Battery to flammable or harsh chemicals or vapors.
 Warning	Do not use fluids, parts, or accessories other than those specified in this manual, including use of non-genuine Apollo parts or accessories, or parts or accessories not purchased directly from Apollo or a Apollo -certified party.
 Warning	Do not place Apollo Battery in a storage condition for more than one (1) month, or permit the electrical feed on the Apollo Battery to be severed for more than one (1) month, without placing Apollo Battery into a storage condition in accordance with Apollo's storage specifications.
 Warning	Do not paint any part of Apollo Battery, including any internal or external components such as the exterior shell or casing.
 Warning	Do not connect Apollo Battery directly to photovoltaic (PV) solar wiring.

1.3 Environmental Conditions





 Warning	Install Apollo Battery at a height that prevents damage from flooding.
 Warning	Operating or storing Apollo Battery in temperatures outside its specified range might cause damage to Apollo Battery.
 Warning	Do not expose the Apollo Battery to ambient temperatures above 55°C (131°F) or below -20°C (-4°F).
 Warning	Ensure that no water sources are above or near Apollo Battery, including downspouts, sprinklers, or faucets.

1.4 Symbol on the Battery Label

Symbol	Description
	Do not sit or put heavy things on product.
	Do not drop, deform, impact, cut or spearing with a sharp object.
	Do not place close to open flame or flammable material.
	Do not place at a children's or pet's reach.

Symbol	Description
	Electric shock hazard, live parts, risk of electric shock, do not touch.
	If fire, switch off the breaker on DC side and stay away from battery.
	Please read the instructions carefully before installation.
	The battery cannot be disposed of with household waste.

1.5 Symbol on the Packing Box

Symbol	Description
	Handle with care.
	This side up.
	Keep dry.
	Stacked layers.

2 Battery Introduction

2.1 Appearance Introduction

2.1.1 Modules

2.1.1.1 Control Module

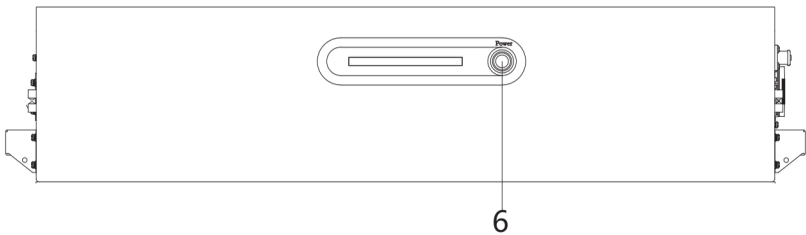
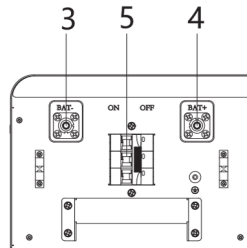
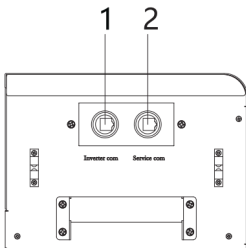
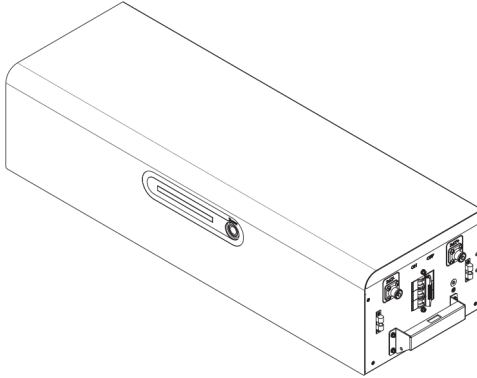

Item	Terminal	Note
1	Inverter COM	Connect to the inverter communication port
2	Service COM	Specified Debug Interface
3	Battery output -	/
4	Battery output +	/
5	Battery MCB	Control battery output
6	Power button	Turn the battery on and off

2.1.1.2 Battery Module

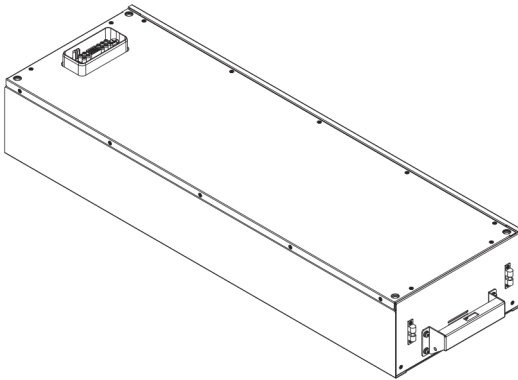

2.1.1.3 Base

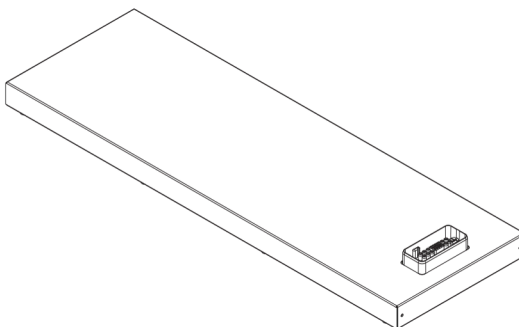

2.2 Packing List

The package includes 1PCS control battery module, 1-9PCS slave battery modules, and 1PCS battery base and other installation accessories. Please check if the battery modules and accessories are complete in the package when receiving the goods, See the following figure for your reference.

Master module packing list

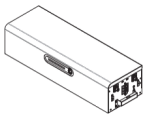

Control Battery
Module×1 PCS



Left side cover assembly
× 1PCS



Right side cover assembly
× 1PCS



Fixed bracket
×2PCS



Battery connection wire of
positive pole ×1 PCS



Battery connection wire of
negative pole×1 PCS



M3-8Countersunk screw
× 4PCS



M4-10 Cross head
combination screw×5PCS



8-60Expansion screw
×4PCS



OT-RNB5.5-4LTerminal
×1PCS



User Manual
×1PCS



Quality Certificate
×1PCS

Slave module packing list

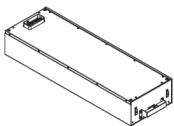

Slave Battery Module×
1~9 1PCS

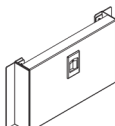

Left side cover assembly
× 1PCS

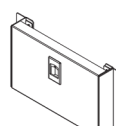

Right side cover assembly
× 1PCS



Alignment pin
×4PCS



Quality Certificate
×1PCS



M3-8Countersunk screw
× 4PCS

Base packing list

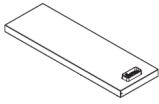

Base
×1PCS

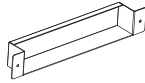

Side cover assembly
×2PCS



Alignment pin
×4PCS



M3-8Countersunk screw
×4PCS



Quality Certificate
×1PCS

3 Installation

3.1 Location Requirements

- ① The area is completely water proof. The floor is flat and level.
- ② There are no flammable or explosive materials.
- ③ The ambient temperature is within the range from -20 to 55 degree.
- ④ The temperature and humidity are maintained at a constant level. There is minimal dust and dirt in the area.
- ⑤ The distance from heat source is more than 2 meters.
- ⑥ Keep the distance of the whole battery system from the air outlet more than 0.5m. Do not cover or wrap the battery cabinet please!
- ⑦ Keep the battery out of kids' and pets' reach please. There should be no direct sunlight at the installation location.
- ⑧ There are no mandatory ventilation requirements for battery module, but please avoid installation in confined space (Installation to the wall should between 0-13mm).
- ⑨ The aeration shall avoid of high salinity.
- ⑩ Make sure the load capacity of the floor not less than 500KG.

3.2 Mounting

3.2.1 Install the Base

- ① Check the installation environment to ensure ground level.
- ② Place the base on the ground, and make sure it is level and stable.

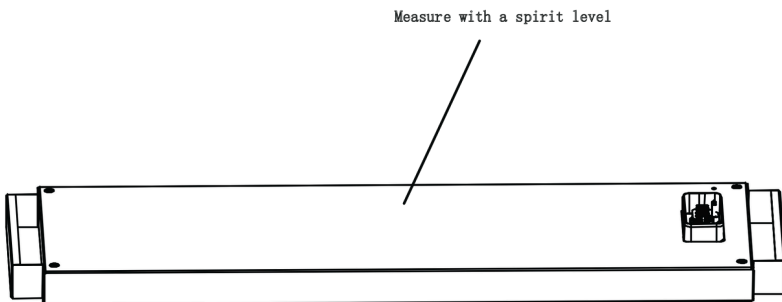

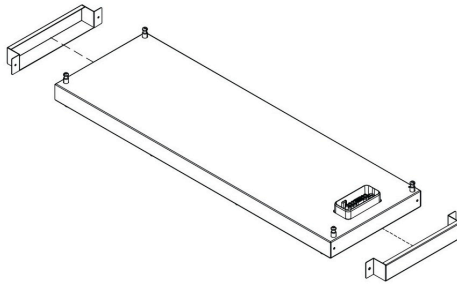

- ③ Distance between base and wall is 0mm~13mm.

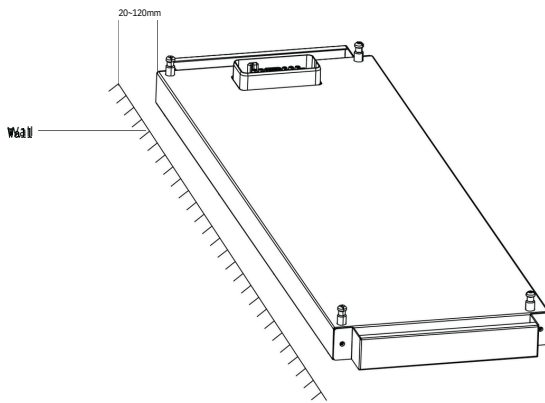

3.2.2 Install the Module

- ① After the base is installed, remove the protective film of the terminals, and the remaining battery module and control module are then placed in turn.

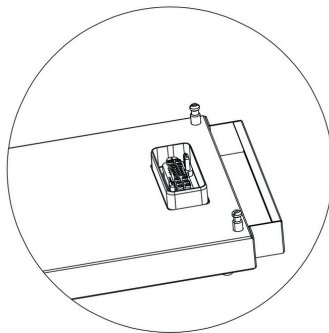



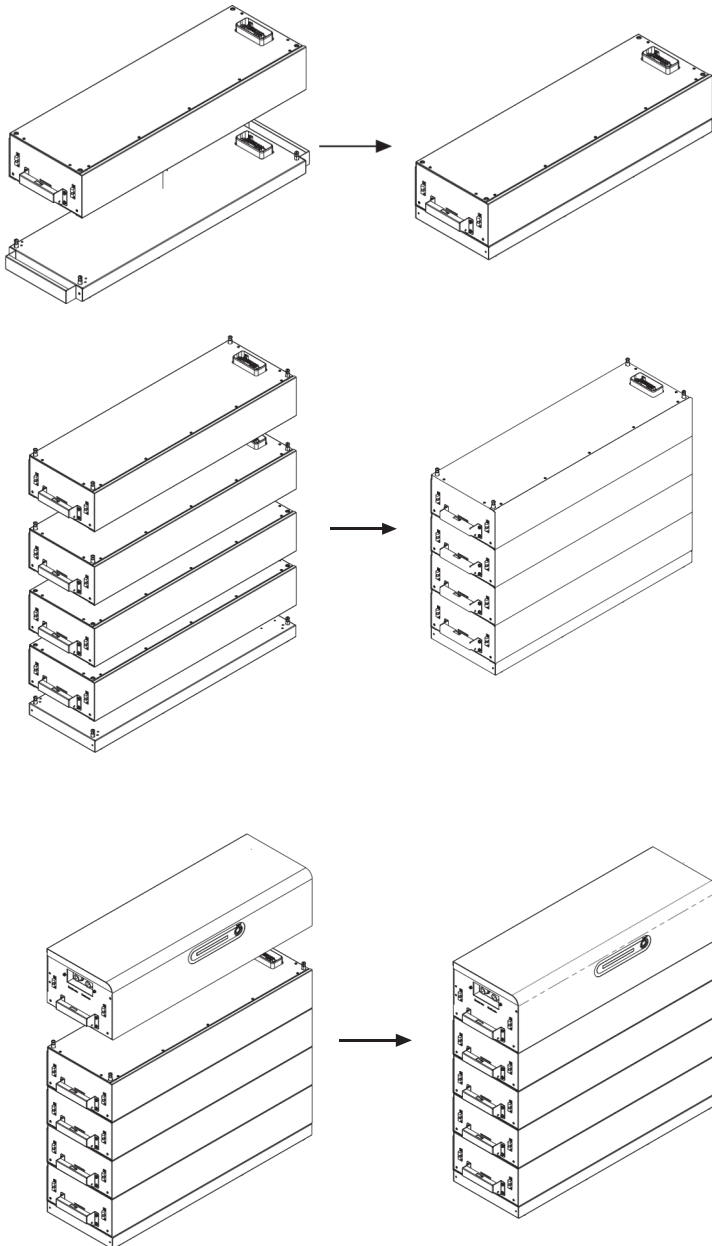

② Install the battery on the base, the terminals on the bottom of the battery should correctly installed to the terminals on the base.

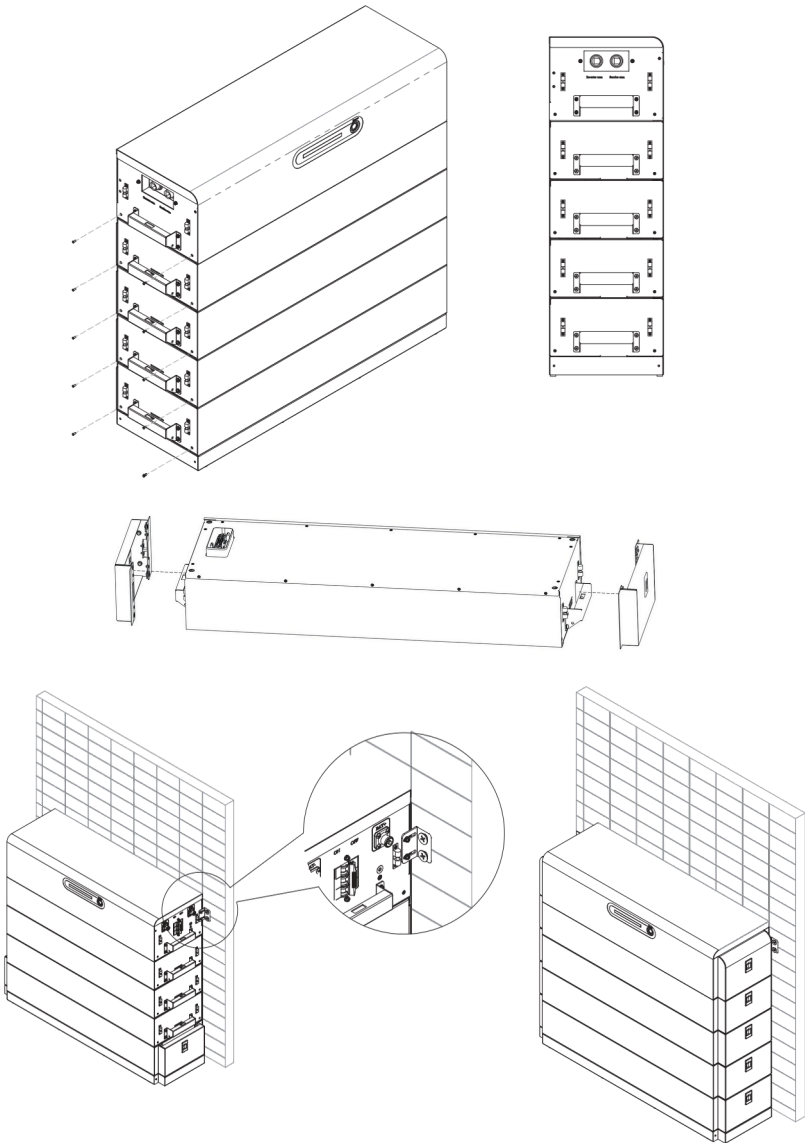

- ③ Install cover plates on both sides of the base and battery module (no need to disassemble, just install from the side after installing the battery module).



4 Electrical Connection

 Warning	<p>A high voltage in the conductive part of the battery may cause an electric shock. When installing the battery, make sure that the DC sides of the battery is completely deenergized.</p>
 Warning	<p>Do not ground the positive or negative pole of the battery output, otherwise it will cause serious damage to the battery.</p>
 Warning	<p>Static may cause damage to the electronic components of the battery. Anti- static measures should be taken during installation and maintenance.</p>
 Warning	<p>Do not use other brands or other types of terminals other than the terminals in the accessory package. The Company has the right to refuse to held liable of all damages caused by the mixed-use of terminals.</p>
 Warning	<p>Moisture and dust can damage the battery, ensure the cable gland is securely tightened during installation. The warranty claim will be invalidated if the battery is damaged as a result of using poorly connected cable connector.</p>

4.1 Cables Connection

After the mechanical installation is completed, please connect the inverter and the control battery module with the positive and negative cables, communication and ground cables.

The picture on this page shows the cables connection. Please follow the instruction and make sure all the cables are connected correctly.

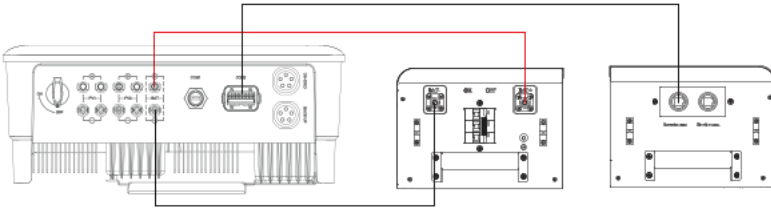

4.2 Battery Power Connector Assembly Procedures

Different brand of inverters have different wiring interface for battery connection, please operate according to the inverter user manual.

- ① Disconnect the battery connection wire (one red and one black) from the master module accessory.

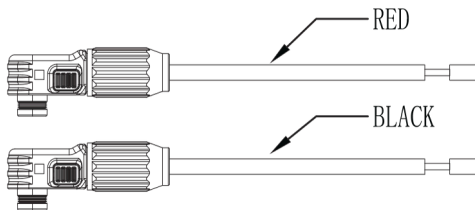

- ② Remove the insulation skin from the other end of the red and black battery connection wire and remove the connector from the inverter accessory.

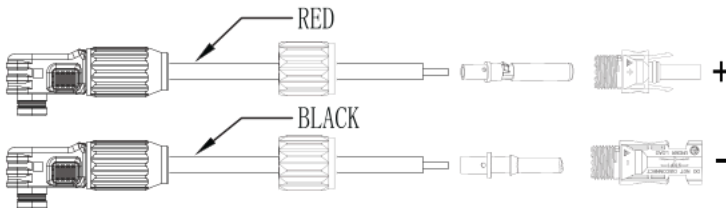

- ③ Insert the battery cable through the battery connector nut into the metal terminal and press the terminal with a professional crimping plier (pull back the cable with some power to check if the terminal is well connected to the cable).

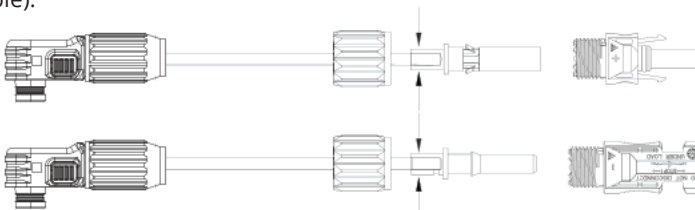

④ Insert the positive and negative cables into the corresponding positive and negative connectors, pull back the battery cable to ensure that the terminal is tightly attached in the connector.

⑤ Use an open-end wrench to screw the nut to the end to ensure that the terminal is well sealed.

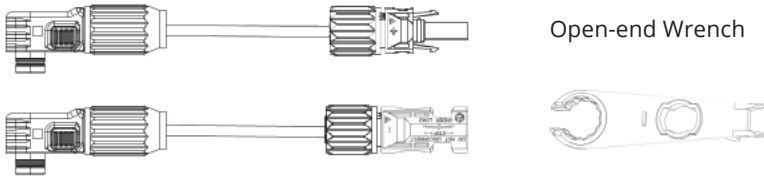

	<p>① Before making the battery connector, please make sure the polarity of the cable is correct.</p>
	<p>② Use a multimeter to measure the voltage of the battery pack and make sure the voltage is within the inverter limitation and the polarity is correct.</p>

⑥ Insert the positive and negative connector into the inverter battery terminals respectively, and a “click” sound represents the assembly in place, as shown in Figure:

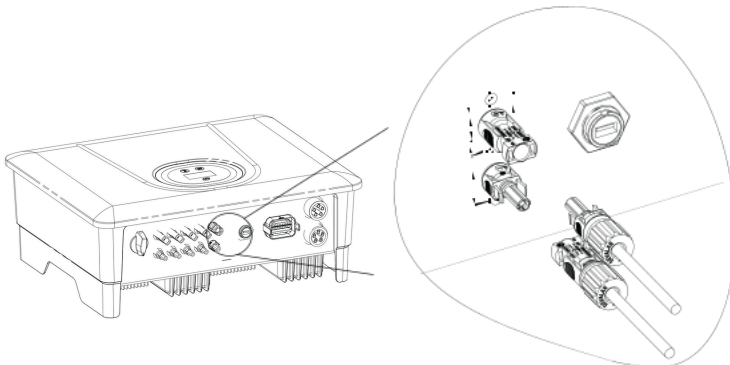

⑦ Insert the positive and negative connector into the battery power terminal-respectively and a "click" sound represents the assembly in place.

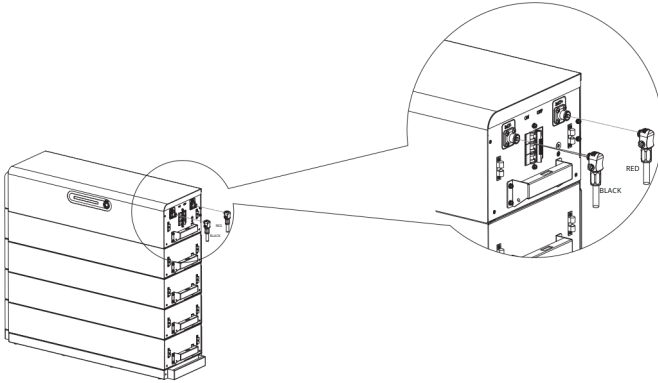

4.3 Communication Cable Connection

One side of the communication cable used to connect the inverter and control module port is preinstalled on the inverter before leaving the factory, insert the other side to the "Inverter COM" port in the control module when installing it. Communication interface and definition:

	Item	Service COM	
	1	RS485_A	
	2	RS485_B	
	3	/	
	4	/	
	5	/	
	6	RS232_RX	
	7	RS232_TX	
8	RS232_GND		

5 System Start and Stop

5.1 Start System

When starting the system, follow these steps:

- ① Turn on the DC Switch in the bottom of inverter.
- ② Turn on the DC Switch on the control module.

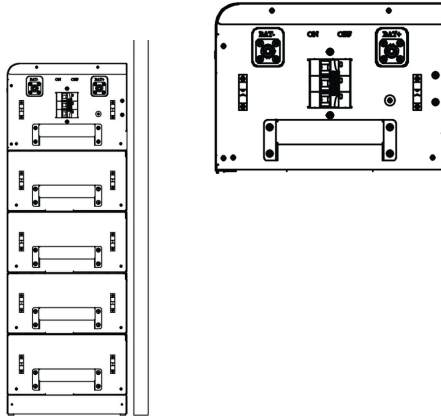

- ③ Hold down the POWER button for 5 seconds until the power button lights up.

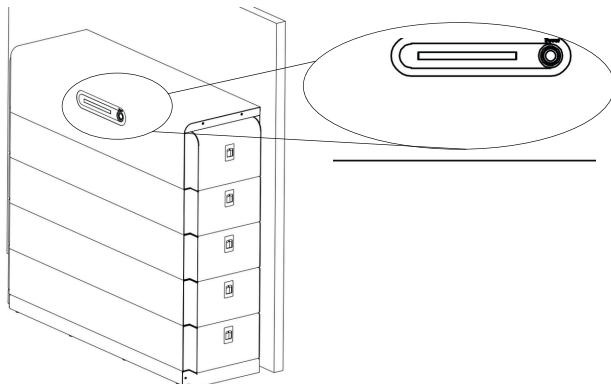

- ④ Observe the status indicator , green light flashing indicates the normal output.
- ⑤ Switch on the AC breaker first.
- ⑥ The inverter will start to check the DC and AC input parameters and self-check for 30s~1min, and if everything is normal, the inverter will start to work according to the working mode which you set on the App. The inverter display and indicators will show relevant parameters and status.

5.2 Turning Off The System

When turning off the system, please follow the steps below:

- ① Switch off the breakers on the grid and load side.
- ② Turn off the DC Switch on the control module.
- ③ Wait 30 seconds and then turn the inverter DC switch to the "OFF". At this time, there is remaining power in the inverter capacitor. Wait for 5 minutes until the inverter is completely de-energized before operating.
- ④ If the device is not used for a long time, please unplug the AC and DC cables.

5.3 LED indication

LED status

Battery Status	Protection, alarm normal	RUN	ALM	Capacity				Description
		Green	Red	Green	Green	Green	Green	
Off		Off	Off	Off	Off	Off	Off	All off
On	Normal	Flash 1	Off	Based on capacity				No charging or discharging
	Warning	Flash 1	Flash 3					PACK low voltage
Charge	Normal	ON	Off	Based on capacity, the highest level LED flashes (flash 2), the other SOC lights is on all the times.				
	Warning	ON	Flash 3					
	Over Charge	On	Off	On	On	On	On	Stop charging
	Over Temp/Current, Failure	Off	On	Off	Off	Off	Off	
Discharge	Normal	Flash 3	Off	Based on capacity, the highest level LED flashes, the other SOC lights is on all the times.				
	Warning	Flash 3	Flash 3					
	Over Discharge	Off	Off	Off	Off	Off	Off	Stop discharging
	Over Temp/Current, Failure	Off	On	Off	Off	Off	Off	
Failure		Off	On	Off	Off	Off	Off	Stop charging and discharging

SOC status

Status		Charge				Discharge			
		L1	L2	L3	L4	L1	L2	L3	L4
Capacity	0~25%	Flash 2	Off	Off	Off	On	Off	Off	Off
	25%~50%	On	Flash 2	Off	Off	On	On	Off	Off
	50%~75%	On	On	Flash 2	Off	On	On	On	Off
	75%~100%	On	On	On	Flash 2	On	On	On	On
Run		On				Flash 3			

Flash description:





Flash 1: 0.25s on/3.75s off

Flash 2: 0.5s on /0.5s off

Flash 3: 0.5s on, 1.5s off

6 Troubleshooting

6.1 Maintenance

 Warning	Risk of battery damage or personal injury due to incorrect service!
 Warning	Keep unqualified persons away!
 Warning	Restart the battery only after removing the fault that impairs safety performance. Never arbitrarily replace any internal components.
 Warning	Servicing of the device in accordance with the manual should never be undertaken in the absence of proper tools, test equipment or the latest revision of the manual which has been clearly and thoroughly understood.

6.2 Maintenance of electrical components

Item	Project	Checkpoint	Methods	Repair Condition	
1	Electrical	Check whether the voltage output is normal.	Multi-mete	The battery voltage exceeds the preset range	Contact the dealer or manufacturer.
2	Failure to check	Check whether the light is normal.	Visual inspection	Warning	
3	Cable	Insulation, terminal	Visual inspection	Insulation crack, aging, the terminal is peeling or corroded.	Replace the cable, replace the terminal board.

6.3 Battery Maintenance

Item	Frequency	Project	Solution
1	Every month	Working environment	Keep away from heat sources and direct sunlight.
		Visual inspection	If there is damage, leakage or deformation, isolate the faulty battery pack, take photos and replace the battery.
2	Every quarter	Visual inspection	Clean appearance with cotton cloth. Be careful when cleaning.
		Connection status	Check whether the wiring is tight, check the temperature of the wire.
3	Half a year	Measure and record voltage	Collect discharge data at least once every six months in the first year. In the second year, discharge data were collected every three months. Check the historical records through the RS232 port. If the alarm information shows that the battery is frequently overcharged, the battery has reached the charging and discharging protection point. This may lead to insufficient time for power preparation. It is recommended to replace the battery immediately.

7 Technical Parameters

Model	512	768	1024	1280	1536
Electrical parameters					
NO. Of Series Battery	2	3	4	5	6
Rated Energy (kwh)	5.12	7.68	10.24	12.8	15.36
Usable Energy (kwh)	4.6	6.9	9.2	11.52	13.8
Rated Voltage (V)	102.4	153.6	204.8	256.0	307.2
Voltage Range (V)	89.6~115.2	134.4~172.8	179.2~230.4	224.0~288.0	268.8~345.6
Battery Type	Li-ion (LFP)				
Rated Capacity(Ah)	50Ah				
Charge Current(A)	25A (Rated) /50A (Maximum)				
Discharge Current (A)	25A (Rated) /50A (Maximum)				
Cycle Times	80% DOD, >10000 times, Remaining capacity >60%				
Communication	RS-485 / RS-232 / CAN 2.0				
Protection function	Over voltage / Under voltage / Over temperature / Low temperature / Over current / Short circuit				
Working conditions					
Installation conditions	Indoor				
Range of working temperature	Charge: 0°C~55°C Discharge: -20°C~55°C				
Optimal working temperature range	20°C~30°C				
Storage temperature	-20°C~55°C				
Working humidity	5%-95% (No condensation)				
Altitude	≤2000m				
Cooling method	Natural cooling				
Certificate	CE, UN38.3, MSDS				
Size [W x H x D, mm]	851*368*255	851*498*255	851*628*255	851*758*255	851*888*255
Weight [kg]	73	104	135	166	197

Model	1792	2048	2304	2560
Electrical parameters				
NO. Of Series Battery	7	8	9	10
Rated Energy (kwh)	17.92	20.48	23.04	25.60
Usable Energy (kwh)	16.1	18.4	20.7	23
Rated Voltage (V)	358.4	409.6	460.8	512
Voltage Range (V)	313.6~403.2	358.4~460.8	403.2~518.4	448~576
Battery Type	Li-ion (LFP)			
Rated Capacity(Ah)	50Ah			
Charge Current(A)	25A (Rated) /50A (Maximum)			
Discharge Current (A)	25A (Rated) /50A (Maximum)			
Cycle Times	80% DOD, >10000 times, Remaining capacity >60%			
Communication	RS-485 / RS-232 / CAN 2.0			
Protection function	Over voltage / Under voltage / Over temperature / Low temperature / Over current / Short circuit			
Working conditions				
Installation conditions	Indoor			
Range of working temperature	Charge: 0°C~55°C Discharge: -20°C~55°C			
Optimal working temperature range	20°C~30°C			
Storage temperature	-20°C~55°C			
Working humidity	5%-95% (No condensation)			
Altitude	≤2000m			
Cooling method	Natural cooling			
Certificate	CE, UN38.3, MSDS			
Size [W x H x D, mm]	851*1018*255	851*1148*255	851*1278*255	851*1408*255
Weight [kg]	228	259	290	321