



Take your power with you 

# Titan User Manual

## Off-Grid Inverter Titan Series



Please visit our website [www.srportables.com](http://www.srportables.com) to register your product.

# Contents

<b>1 Notes on this Manual</b> .....	02
1.1 Scope.....	02
1.2 Target Group.....	02
1.3 Symbols Used.....	02
<b>2 Safety</b> .....	03
2.1 Important Safety Instructions.....	03
2.2 Explanation of Symbols .....	04
<b>3 Introduction</b> .....	05
3.1 Scope of Application .....	05
3.2 Product Model Description .....	05
3.3 Working Mode Introduction .....	06
3.4 Datasheet.....	09
<b>4 Installation Instructions</b> .....	10
4.1 Safety Tips .....	10
4.2 Packing List .....	10
4.3 Determine the Installation Method and Location.....	12
4.4 Installation.....	13
<b>5 Electrical Connections</b> .....	17
5.1 Electrical Interface Description .....	17
5.2 System Wiring Schematic .....	18
5.3 Battery Wiring .....	19
5.4 PV Input Wiring.....	21
5.5 AC in/AC out Wiring.....	22
5.6 Monitor Installation (Optional) .....	25
<b>6 Local Configuration</b> .....	26
6.1 Local Interface Introduction.....	26
6.2 Home Page.....	26
6.3 Detail Info Page.....	27
6.4 Fault Page .....	29
6.5 Statistics Page .....	30
6.6 Setting Page.....	30
6.7 Start up the System.....	40
6.8 Shut Down the System.....	40
<b>7 Failure Codes and Countermeasures</b> .....	41
<b>8 System Maintenance</b> .....	45
8.1 Storage .....	45
8.2 Cleanliness.....	45

# 1 Notes on this Manual

## 1.1 Scope

This manual is an integral part of Titan.

Off-Grid Inverter	
Titan 6.2KS	Titan 8~12KS

This manual describes the assembly, installation, commissioning, maintenance and failure of the product. Please read it carefully before operating.





The manual is only for this batch of shipment.

## 1.2 Target Group

This manual is for qualified electricians. The tasks described in this manual only can be performed by qualified personnel.

## 1.3 Symbols Used

The following types of safety instructions and general information appear in this document as described below:

 Danger	<b>Danger!</b> "Danger" indicates a hazardous situation which, if not avoided, will result in death or serious injury.
 Warning	<b>Warning!</b> "Warning" indicates a hazardous situation which, if not avoided, could result in death or serious injury.
 Caution	<b>Caution!</b> "Caution" indicates a hazardous situation which, if not avoided, could result in minor or moderate injury.
	<b>Note!</b> "Note" provides tips that are valuable for the optimal operation of our product.

## 2 Safety

### 2.1 Important Safety Instructions





#### **Danger!**

- Electric shock and high voltage.
- Do not expose the system to temperatures in excess of 45°C.
- Do not subject the system to any strong force.
- Do not touch uninsulated cable termination.
- Do not soak the system in water or expose it to moisture environment.
- Do not touch the case of the system when it is wet in case of electric shock.
- Do not place the system near a heat source, such as direct sunlight, a fireplace.
- Keep inflammable and explosive dangerous items or flames away from the system.
- Do not charge or discharge damaged system.
- Before performing any work on the system, please disconnect the system from all voltage sources as described in this document.









#### **Warning!**

- Installation, repair, recycling, and disposal of system must be performed by qualified personnel in accordance with national and local standards and regulations.
- Risks of chemical burn electrolyte or toxic gases.
- Do not place heavy objects on the top of the system.
- If the moisture penetrates the system (e.g., due to casing damage), please do not install or operate the system.
- Do not use wet hands to touch the system.
- Any behavior to change the functionality of the product without permission will cause fatal injury to the operator, third parties, and equipment. Titan is not responsible for these losses and warranty claims.
- To ensure property and personal safety, the Titan shall be well grounded.

	<p><b>Caution!</b></p> <ul style="list-style-type: none"> <li>• Do not modify or tamper with system and other components of the system.</li> <li>• Risk of injury by hoisting or falling system.</li> <li>• Titan is heavy and personal injury can be caused if the Titan is improperly lifted or dropped during transport or improper operation when attached or removed from walls. Lifting and moved the products shall be conducted by more than two people.</li> </ul>
	<p><b>Note!</b></p> <ul style="list-style-type: none"> <li>• Do not reverse output of these two AC terminals of the Titan.</li> </ul>

## 2.2 Explanation of Symbols

This section explains all the symbols shown on the Titan and on the type label.

	<p>CE mark. The system complies with the requirements of the applicable CE guild lines.</p>
	<p>Dangerous electrical voltage The device is directly connected to public grid, thus all work to the system shall only be carried out by qualified personnel. Do not touch any internal parts of the Titan being disconnected from the mains, battery and PV input for 5 minutes.</p>
	<p>Danger of hot surface The components inside the device will release a lot of heat during operation. Do not touch metal plate housing of the Titan during operating.</p>
	<p>Danger. Risk of electric shock!</p>
	<p>An error occurred Read the usage manual to troubleshoot problems</p>
	<p>Recyclable</p>

## 3 Introduction

### 3.1 Scope of Application

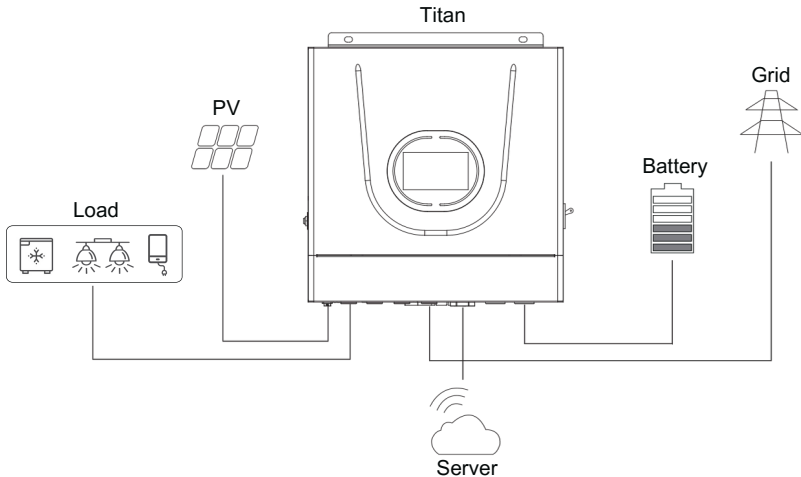

In daytime, solar power supports the loads first while the surplus power will be stored by system, to improve self-consumption rate.

In case of grid fault, system will make sure no outage in the loads, achieving UPS function.

### 3.2 Product Model Description



Titan - 6.2K    S  
 ①            ②            ③

- ① Titan is the name of Off-Grid Inverter.
- ② 6.2K indicates the rated power of the system, such as 6.2K for 6.2kW.
- ③ S indicates that the system is a single-phase system.

### 3.3 Working Mode Introduction

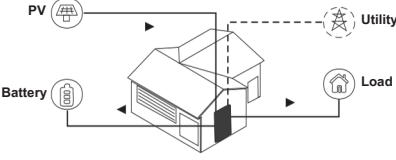
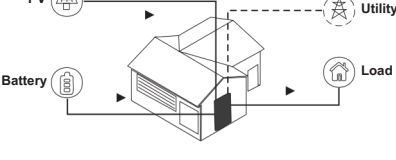
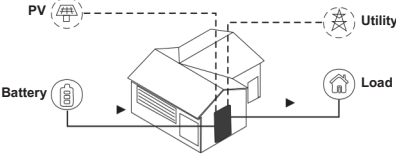
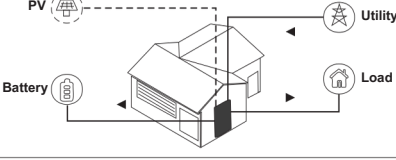
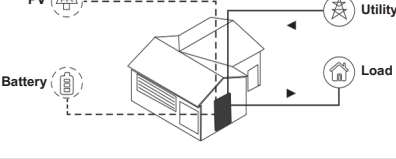
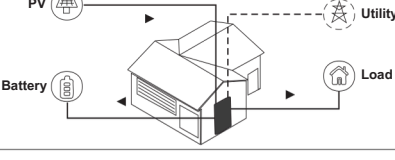
<b>Work Mode: Uti First (Grid priority output)</b>	
	<p>When the charging mode is set Pv&amp;Uti/Pv First: There is no PV, the grid prioritizes the output of the load while charging the battery y.</p>
	<p>When the charging mode is set Pv Only: There is no PV, the grid prioritizes load output and the battery is on standby.</p>
	<p>When the charging mode is set Pv&amp;Uti/Pv First: The grid prioritizes the output to the load, the PV charges the battery, and when the battery charging current is high, the shortfall is supplemented by the grid.</p>
	<p>When the charging mode is set Pv Only: The grid prioritizes output to the load, the PV charges the battery, and the grid does not charge the battery.</p>
<b>Work Mode: Pv First (PV priority output)</b>	
	<p>When the charging mode is set Pv&amp;Uti/Pv First: There is no PV, the grid prioritizes the output of the load while charging the battery y.</p>
	<p>When the charging mode is set Pv Only: There is no PV, grid output load and no charging, battery standby.</p>

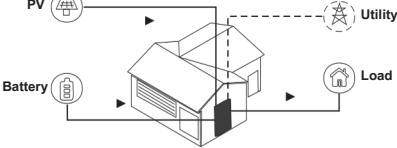
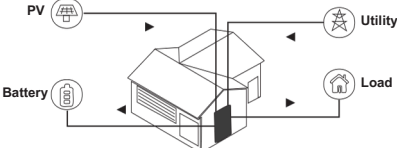
	<p>When charging mode setting Pv&amp;Uti/Pv First/Pv Only:                  PV power &gt; load power, PV carries and charges, charging current depends on remaining PV energy; utility standby.</p>
	<p>When the charging mode is set to PV &amp; Uti / PV First / PV Only:                  If the PV power is less than the load power, the battery supplements the load power, and the grid remains unloaded.</p>
<p><b>Work Mode: Bat First (PV first, Battery second, Grid third output)</b></p>	
<p>Mode 1:</p> 	<p>When there is no PV and the charging mode is set Pv&amp;Uti/Pv First:</p> <p>Mode 1: Battery power &gt; load power, battery output to load, utility standby.</p>
<p>Mode 2:</p> 	<p>Mode 2: Battery power &lt; load power (Battery SOC &lt; "Batt. Switch to AC SOC"), grid carry and charge until Battery SOC &gt; "AC Switch to Batt. SOC", switch to mode 1.</p>
	<p>When the charging mode is set Pv Only:                  There is no PV, battery power &lt; load power (SOC &lt; "Batt. Switch to AC SOC"), grid loaded, battery standby.</p>
	<p>When charging mode setting Pv&amp;Uti/Pv First/Pv Only:                  PV power &gt; load power, PV with load and charging, charging current depends on PV residual energy, utility standby.</p>

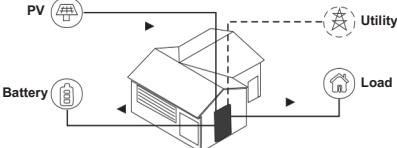
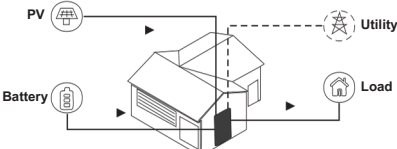
<p>Mode 1:</p> 	<p>When PV power &lt; load power:</p>
<p>Mode 2:</p> 	<p>Mode 1: PV + battery together with load, utility standby.</p> <p>Mode 2: When the charging mode is set to Pv&amp;Uti/Pv First and the battery SOC &lt; "Batt. switching to AC SOC", utility output to load, utility + PV to charge battery (PV priority), charge until Battery SOC &gt; "AC Switch to Batt. Switch to Batt. SOC", turn to Mode 1.</p>
<p>Mode 3:</p> 	<p>Mode 3: When the charging mode is set to Pv Only and the battery SOC &lt; "Batt. switch to AC SOC", utility output to load, PV charging to Battery SOC &gt; "AC Switch to Batt. SOC", turn to Mode 1.</p>
<p><b>When the power grid is absent (regardless of operating/charging mode)</b></p>	
	<p>PV power &gt; load power, PV output to the load and charging the battery at the same time.</p>
	<p>PV power &lt; load power, battery power is sufficient, PV and battery output to load at the same time.</p> <p>When battery SOC &lt; "Batt. Switch to AC SOC", stop load output, 15s later PV charge the battery, charge to 52V, stop charging, 8s later PV and battery carry load at the same time.</p>

## 3.4 Datasheet

Model	Titan-6.2KS	Titan-8KS	Titan-10KS	Titan-12KS
<b>Battery</b>				
Rated Voltage	51.2V			
Voltage Range	40~60Vdc±0.6Vdc			
Max. Charge Current	100A	120A	150A	
<b>AC Output (Backup)</b>				
Rated Power	6200W	8000W	10000W	12000W
Rated Output Voltage	230Vac			
Output Frequency	50/60Hz±0.3Hz			
Max Output Current	28.1A	36.3A	45.4A	54.5A
Rated Current	27A	34.7A	43.4A	52.2A
Peak Power	12400W	16000W	20000W	24000W
Over Load Ability	Battery Mode(Battery Max Output Current>200A): 5min@100~110%Load; 10s@110~135%Load; 5s@>135%Load	Battery Mode(Battery Max Output Current>300A): 5min@102~170%Load; 10s@170~200%Load; 5s@>200%Load	Battery Mode(Battery Max Output Current>300A): 5min@102~130%Load; 10s@130~160%Load; 5s@>160%Load	Battery Mode(Battery Max Output Current>300A): 5min@102~110%Load; 10s@110~130%Load; 5s@>130%Load
Peak Efficiency(Battery Mode)	>93%			
Transfer Time	10ms			
<b>AC Input</b>				
Input Sources	L+N+PE			
AC Input Voltage Range	APL Mode:90~280Vac/UPS Mode:170~280Vac			
Rated Input Voltage	208/220/230/240Vac			
AC input frequency	50/60Hz(Auto Adaptive)			
<b>PV Input</b>				
Max PV Input Power	6600W	5500W/5500W	5500W/5500W	6600W/6600W
Number of independent MPPT trackers	1	1/1		
No. of PV strings per MPPT trackers	1	2		
Max. PV Input Voltage	500Vdc			
MPPT Voltage Range	120~450Vdc	90~450Vdc		
Max. DC Input Current	22A	22A/22A		
Max. DC Short Circuit Current	24A	24A/24A		
<b>General Data</b>				
Range of working temperature	0°C~50°C (Charge) / -10°C~55°C (Discharge)			
Storage temperature	-15°C~60°C			
Humidity	5-95%non-condensing			
Cooling strategy	Fan			
Altitude	<2000m			
Weight	10.8kg	20.75kg		
Dimension [W x H x D]	380*377*112 mm	505*460*134 mm		
Enclosure protection rating	IP20			
Communication	Wi-Fi (Optional)/RS485/CAN			
Certification	CE(IEC62109-1,2)			
	EN61000-6-1, EN61000-6-3			

## 4 Installation Instructions











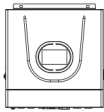

### 4.1 Safety Tips



	<p><b>Danger!</b></p> <ul style="list-style-type: none"> <li>● Potential fires and electric shocks that are life threatening.</li> <li>● Do not place any flammable or explosive materials beside system.</li> <li>● Equipment connected to high-voltage power generation equipment must be</li> </ul> <p>performed by qualified personnel in compliance with national and local standards and regulations.</p>
---	---

	<p><b>Note!</b></p> <ul style="list-style-type: none"> <li>● The pollution level applicable to system is Class II.</li> <li>● Inappropriate or inconsistent installation environment can shorten the life of system.</li> <li>● Do not install Titan directly by exposing it under strong sunlight.</li> <li>● Please do not install in damp places.</li> <li>● The installation location must be well ventilated.</li> </ul>
---	---











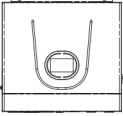





### 4.2 Packing List

#### 4.2.1 Titan-6.2KS Inverter Module Packing List

			
Inverter Module × 1 Pcs	Tube Terminal (Red) × 4 Pcs	Tube Terminal (Black) × 4 Pcs	Tube Terminal (Yellow) × 3 Pcs
			
Monitor Module (Optional) × 1 Pcs	Expansion Screw × 4 Pcs	Network Cable (1.5m) × 1 Pcs	OT Terminal × 2 Pcs
			
Streamline × 1 Pcs	Parallel Line (DB15) × 1 Pcs	RNBS.5-4L × 1 Pcs	User Manual × 1 Pcs

	
Qualified Certificate × 1 Pcs	Packing List × 1 Pcs

### 4.2.2 Titan-8-12KS Inverter Module Packing List

			
Inverter Module × 1 Pcs	WiFi Plug (Optional) × 1 Pcs	Expansion Screw × 3 Pcs	RNB5.5-4L × 1 Pcs
			
Tube Terminal (Red) × 3 Pcs	Tube Terminal (Black) × 3 Pcs	Tube Terminal (Yellow) × 3 Pcs	PV-Tube Terminal (Red) × 2 Pcs
			
PV-Tube Terminal (Black) × 2 Pcs	Network Cable (1.5m) × 1 Pcs	Streamline × 1 Pcs	Parallel Line (DB15) × 1 Pcs
			
OT Terminal × 2 Pcs	User Manual × 1 Pcs	Qualified Certificate × 1 Pcs	Packing List × 1 Pcs

### 4.3 Determine the Installation Method and Location

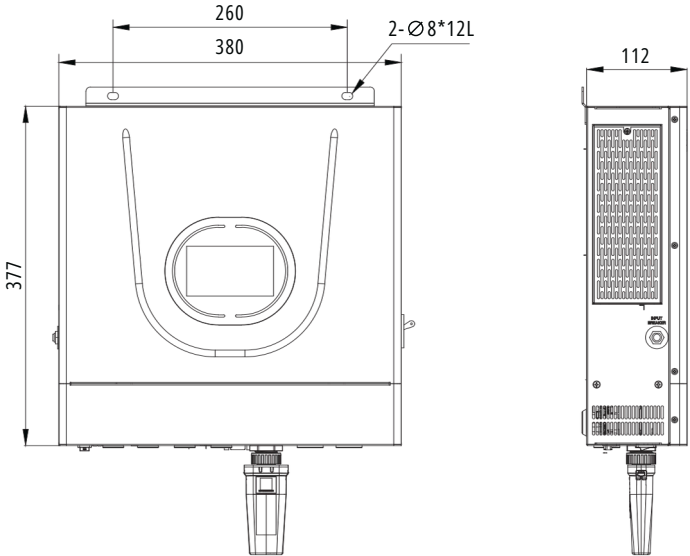



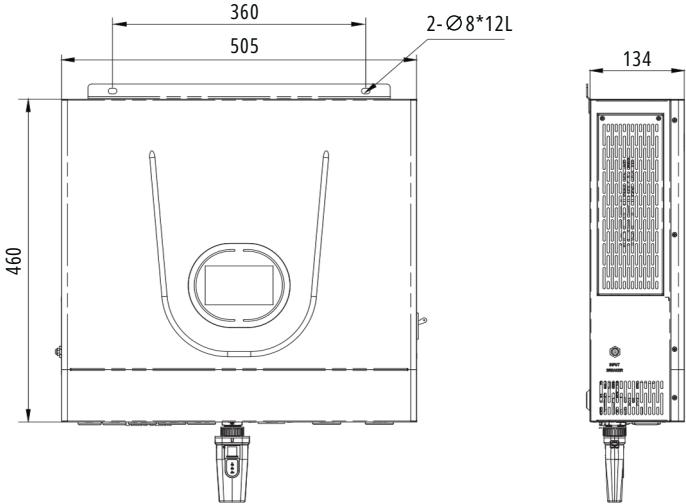



Titan-6.2KS Dimension (mm)

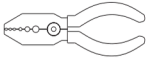

Titan-8-12KS Dimension (mm)

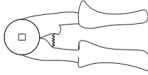
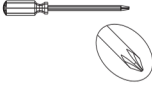
Titan heat dissipation by fan cooling. It is recommended to install in indoors or sheltered areas to avoid direct sunlight, rain and snow. Please ensure that the air at the installation point is circulated. Bad air ventilation will affect the working performance of internal electronic components and shorten the service life of Titan.

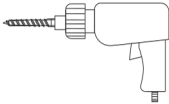
### 4.4 Installation

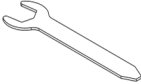
			
Crimper	Knife	Crimping Pliers (Tube Terminals)	Phillips Screwdriver
			
Marker Pen	Electric Drill	Hexagonal Socket Screwdriver (Titan-10KS)	Lever

#### Wall-Mounted Installation

The device shall be indoor installed and vertical placed. The place where it is installed shall be able to ensure the stability and safety of the product.

#### 4.4.1 Titan-6.2KS Installation Step1:

Remove the bottom wiring cover.

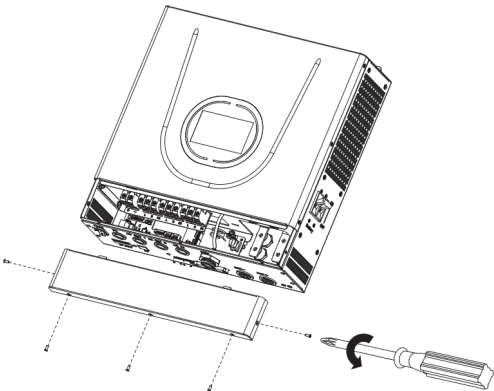

**Step2:** Drilling hole

Choose a suitable location to place the mounting bracket, and there should be no obstructions within 200mm to avoid affecting heat dissipation. Put the mounting bracket properly on the wall, mark these 4 drill holes using a marker pen. Drill 4 holes on the wall, Insert the expansion screw vertically into the hole.

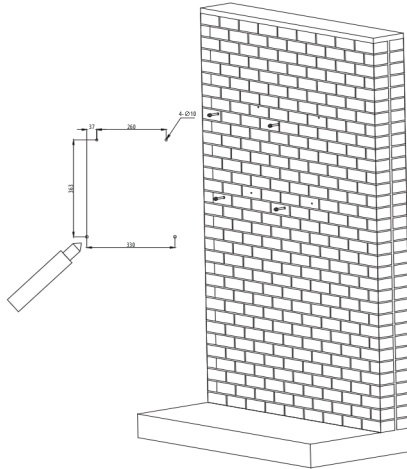

**Step3:** Installation

Lift the Titan up and install it according to the position of the screws on the wall, tighten the nuts after installation.

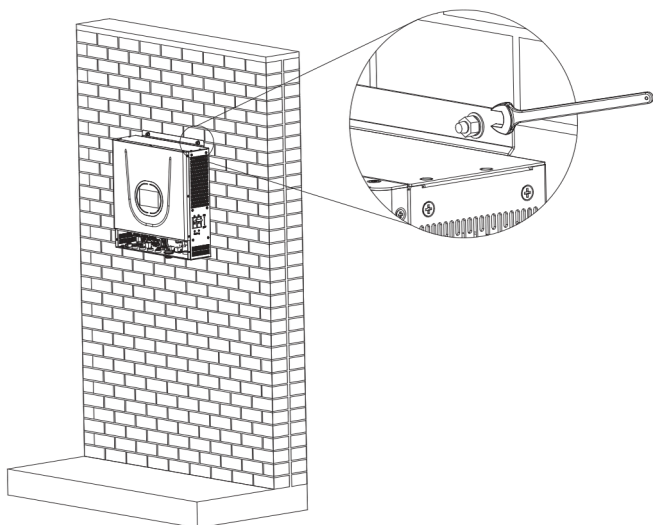

#### 4.4.2 Titan-8-12KS Installation Step1:

Remove the bottom wiring cover.

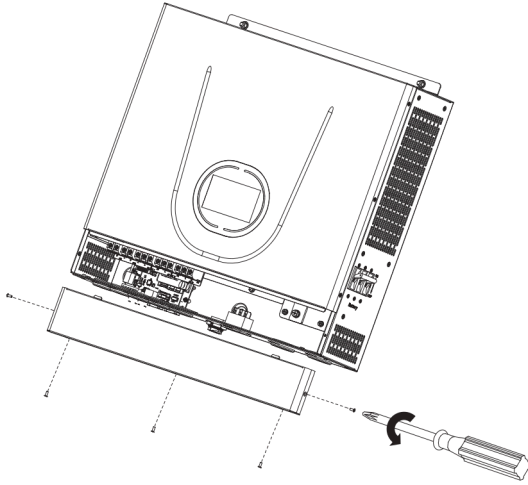

#### Step2: Drilling hole

Choose a suitable location to place the mounting bracket, and there should be no obstructions within 200mm to avoid affecting heat dissipation. Put the mounting bracket properly on the wall, mark these 3 drill holes using a marker pen. Drill 3 holes on the wall, Insert the expansion screw vertically into the hole.

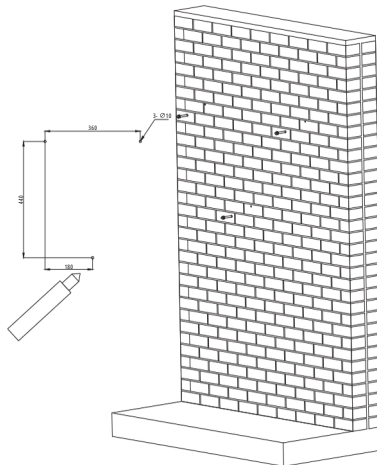

**Step3:** Installation

Lift the Titan up and install it according to the position of the screws on the wall, tighten the nuts after installation.

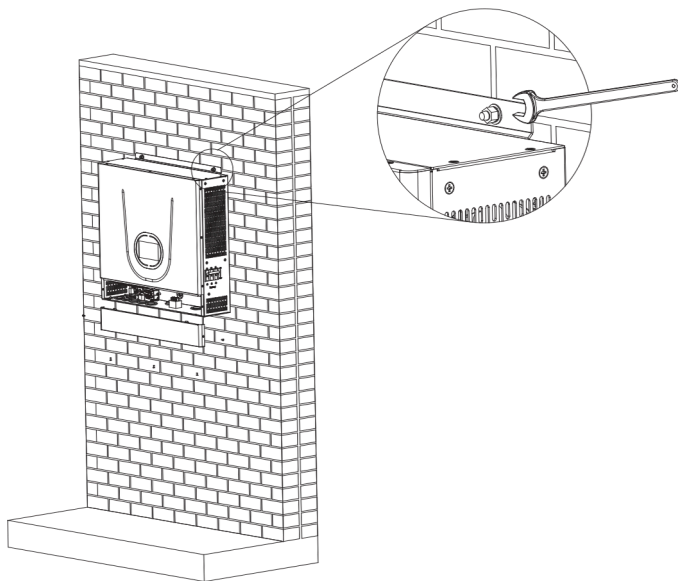

## 5 Electrical Connections

### 5.1 Electrical Interface Description

#### 5.1.1 Titan-6.2KS Inverter Module Interface Description

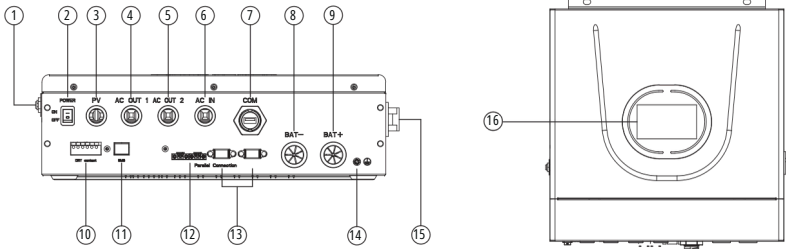

Object	Description	Object	Description
1	Overload Protector Reset Button①	9	Battery Input +
2	Inverter Switch	10	Dry Contact Battery
3	PV Input	11	Communication Port
4	AC Output 1	12	Current sharing port(parallel module only)
5	AC Output 2	13	Parallel communication port
6	AC Input	14	Grounding screw hold
7	COM(Wi-Fi) (Optional)	15	BAT Circuit Breaker
8	Battery Input -	16	LCD Screen

① AC Input Overload Reset Button: The button is in a retracted state by default. If the AC input current exceeds 35A (which may happen during bypass output and battery charging), the button will pop up and disconnect the AC input. To resume AC input, press the button to reset it. If the button keeps popping up, reduce the load or lower the battery charging current.

#### 5.1.2 Titan-8-12KS Inverter Module Interface Description

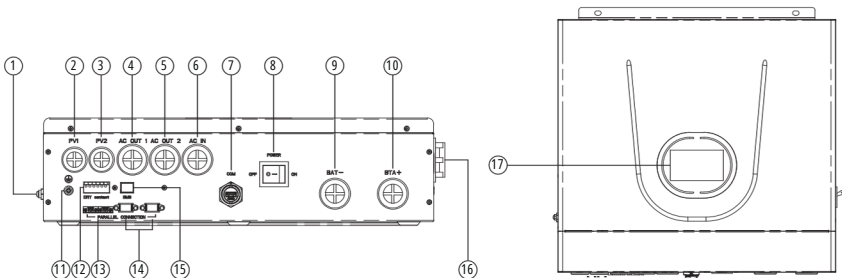

Object	Description	Object	Description
1	Overload Protector Reset Button①	10	Battery Input +
2	PV Input 1	11	Grounding screw hold
3	PV Input 2	12	Dry Contact
4	AC Output 1	13	Current sharing port(parallel module only)
5	AC Output 2	14	Parallel communication port
6	AC Input	15	Battery Communication Port
7	COM(Wi-Fi) (Optional)	16	BAT Circuit Breaker
8	Inverter Switch	17	LCD Screen
9	Battery Input -	18	/

① AC Input Overload Reset Button: The button is in a retracted state by default. If the AC input current exceeds 35A (which may happen during bypass output and battery charging), the button will pop up and disconnect the AC input. To resume AC input, press the button to reset it. If the button keeps popping up, reduce the load or lower the battery charging current.

## 5.2 System Wiring Schematic

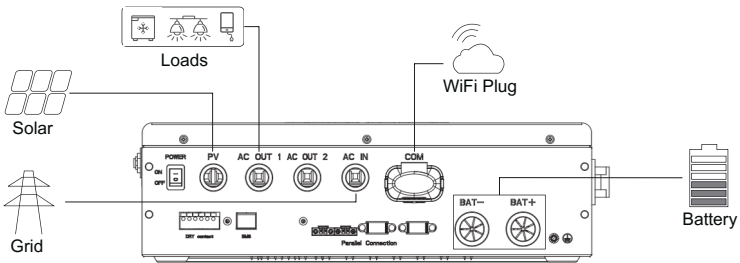

Titan-6.2KS System Wiring Diagram

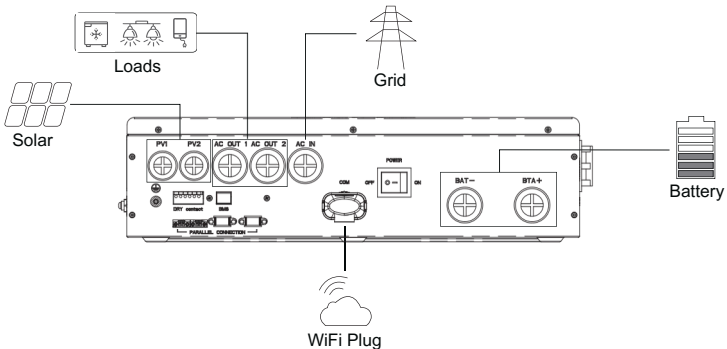

Titan-8-12KS System Wiring Diagram

### 5.3 Battery Wiring

Titan-6.2KS

Cable Type	Core Cross Sectional Area (mm <sup>2</sup> )
4 AWG	25

Titan-8-12KS

Cable Type	Core Cross Sectional Area (mm <sup>2</sup> )
2/0 AWG	70

**Step 1:** Prepare the cable. The stripping operation must not cut any cable strands, insulation or jacket at places other than specified by the cable stripping dimensions. Take care that the individual strands of the cable are not bent and that the insulation or jacket is not damaged. The surface must be clean and free of contamination.



**Step 2:** Apply the cable onto the crimping position

Before crimping, the center terminal must be positioned to fulfill following conditions:

- A max. air gap of 1 mm is allowed between the shoulder of the cable insulation.

Cable	Color
BAT+	Red
BAT-	Black

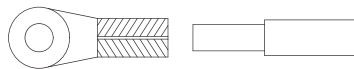

**Step 3:** Use a special tool to crimp the cable to ensure that the crimping is intact.

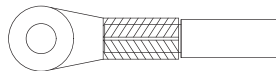

**Step 4:** Unscrew the battery cover screws and lock the positive and negative battery cables.

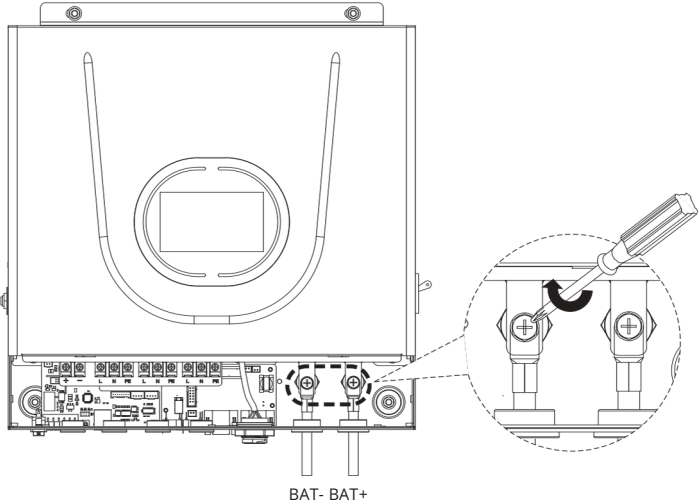

Titan-6.2KS Battery Wiring

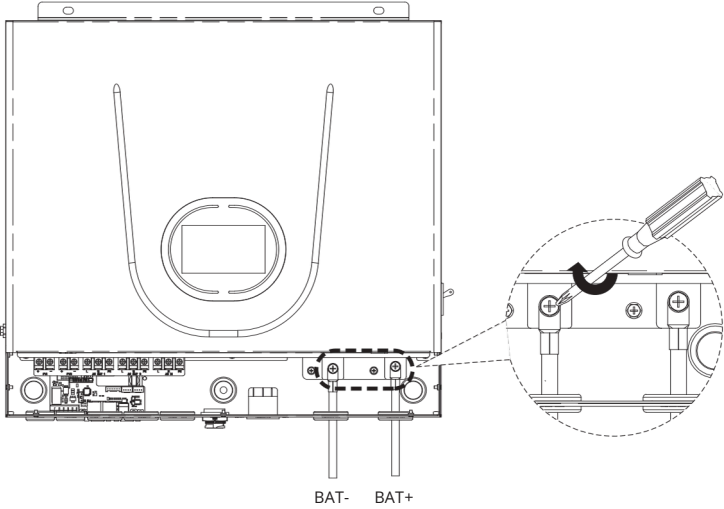

Titan-8-12KS Battery Wiring

## 5.4 PV Input Wiring



### Note!

- Use 4 mm<sup>2</sup> DC cable for the DC input cable.
- Remove the side bezel before installation.

Cable Type	Core Cross Sectional Area (mm <sup>2</sup> )
10 AWG	5-6

**Step 1:** Prepare PV positive and negative power cables.

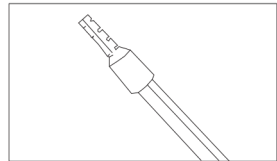
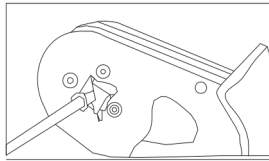
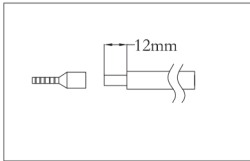

Cable	Color
PV+	Red
PV-	Black

**Step 2:** Insert the crimped photovoltaic positive and negative power cable into the PV Input Terminal.

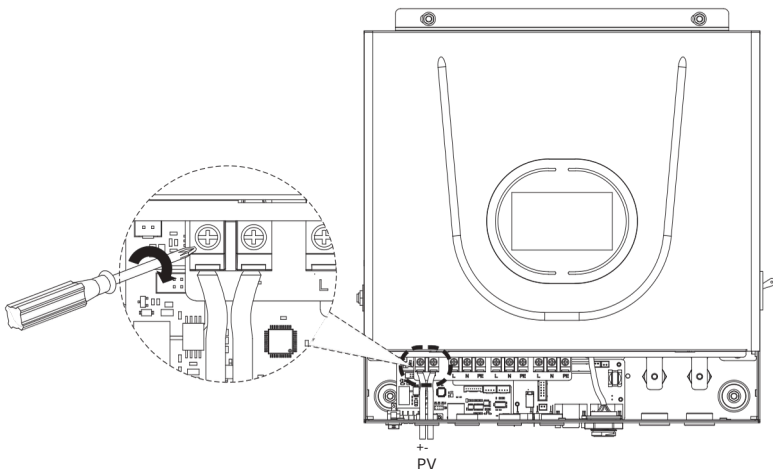

Titan-6.2KS PV Input Wiring

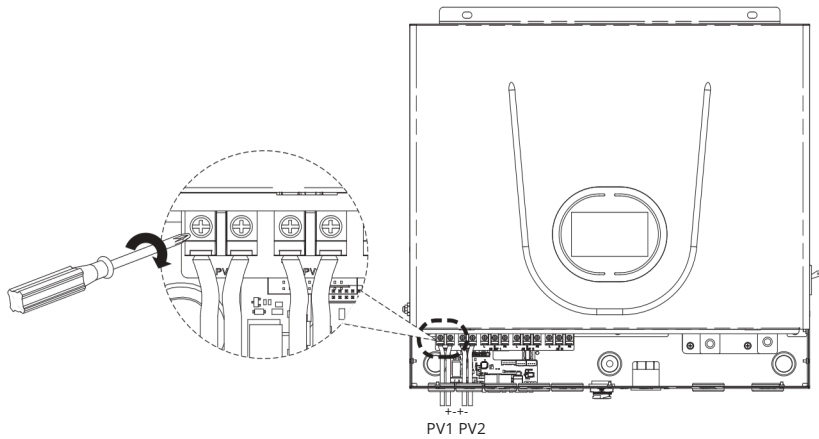

Titan-8-12KS PV Input Wiring



**Warning!**

- Make sure that the DC voltage of each PV string is less than 450V and the polarity of PV cables are correct.
- Ensure wiring is not energized.

### 5.5 AC in/AC out Wiring



**Warning!**

- Turn off the external AC breaker after unpacking in any cases before and during wiring in case of electric shock.

**Step 1:** ① Choose the right cable.

Titan-6.2KS

Cable Type	Core Cross Sectional Area (mm <sup>2</sup> )
10 AWG	5-6

Titan-8-12KS

Cable Type	Core Cross Sectional Area (mm <sup>2</sup> )
8 AWG	8-10

② Peel off the cable insulation sleeve for 12mm, as shown in Figure:

**Step 2:** Crimp terminals with special tools.

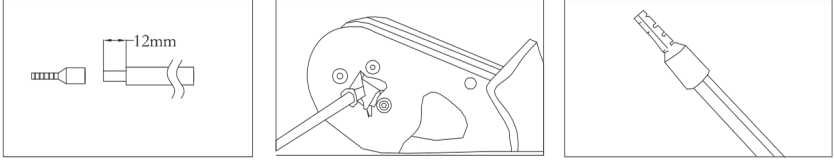

Cable	Color
L	Red
N	Black
PE	Yellow-Green

**Step 3:** Connect cable to AC in/AC out terminals.

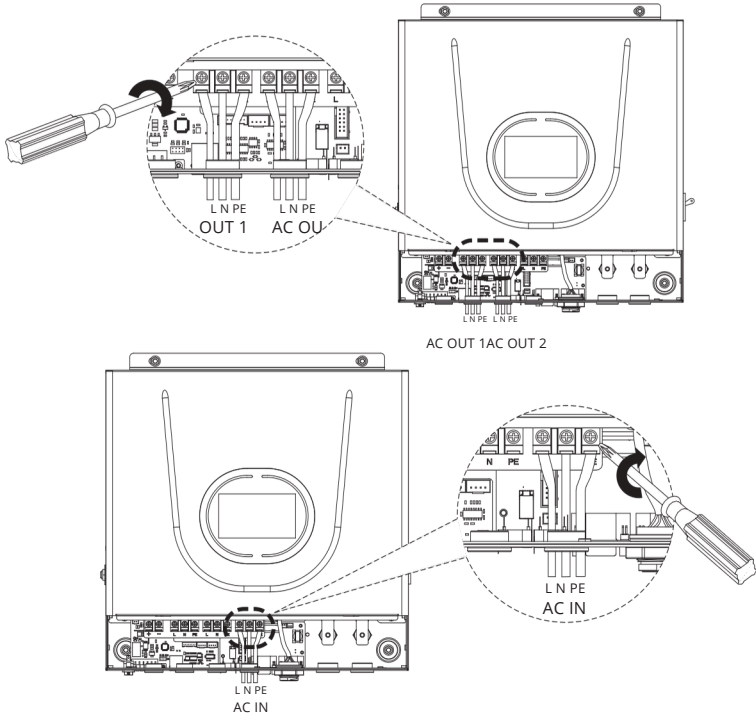

Titan-6.2KS AC in/AC out Wiring

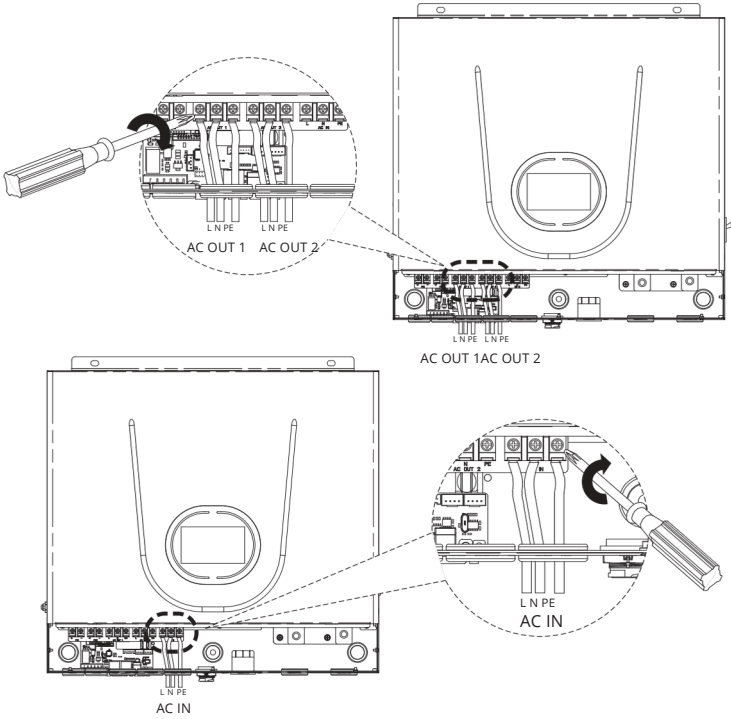

#### Titan-8-12KS AC in/AC out Wiring

**Step 4:** Installation is complete, connect the appropriate wiring harnesses, close the cover, and lock the screws.

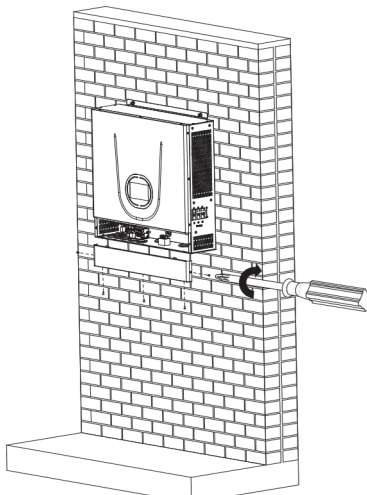

## 5.6 Monitor Installation (Optional)

Installation of monitor. Refer to the monitor's manual (in the packing box) for specific instructions on how to use it.

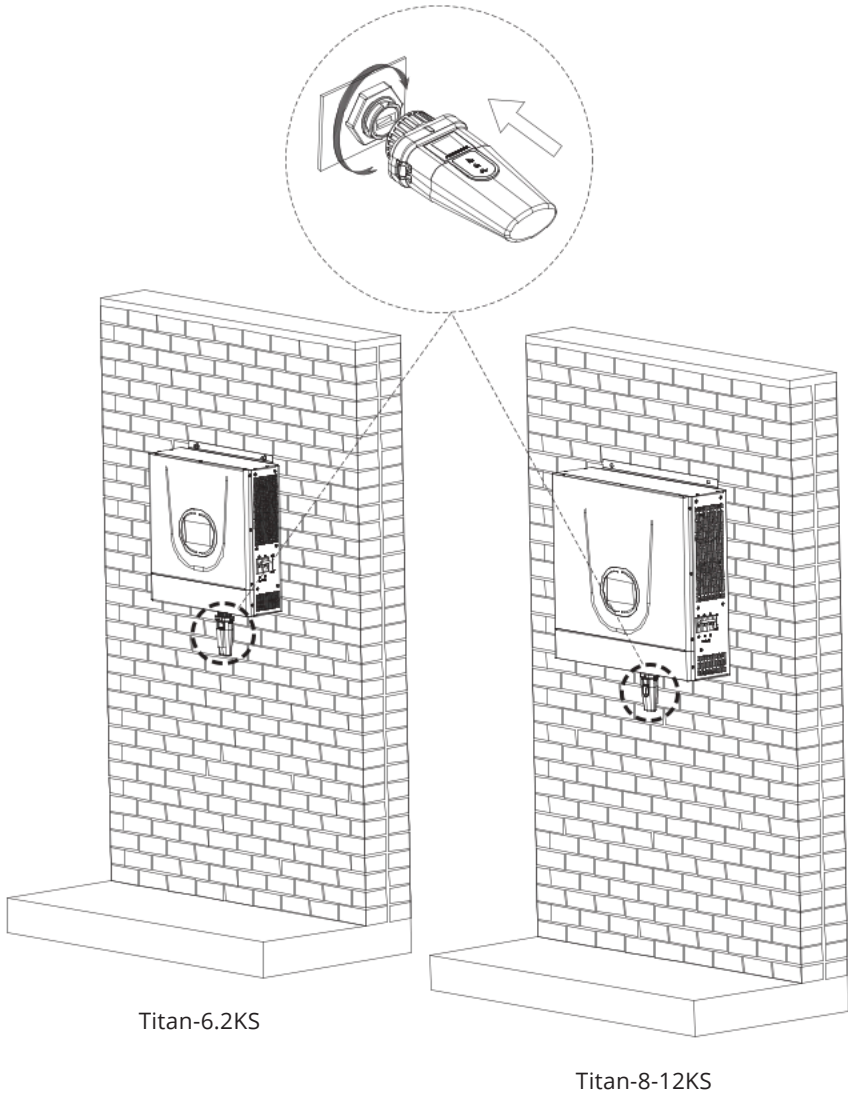



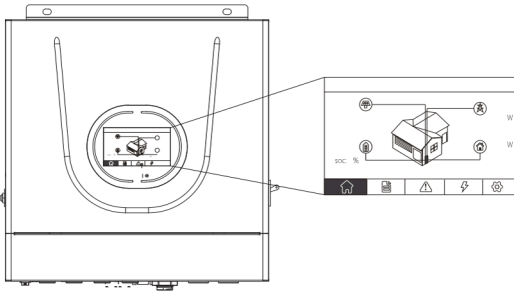

## 6 Local Configuration

### 6.1 Local Interface Introduction

Titan-6.2KS, Titan-8-12KS has a touch screen on the front.



	Home Page
	Detail Info Page
	Fault Page
	Statistics Page
	Setting Page

### 6.2 Home Page

This page shows the total PV input power, AC grid power, battery power and SOC, load power.

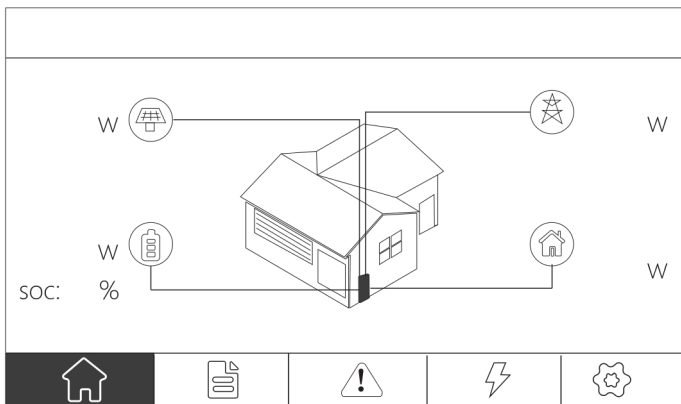

## 6.3 Detail Info Page

### 6.3.1 I/O Info Page

This page  shows the PV, Grid, Load and Battery information.

The display varies slightly from model to model, please refer to the actual screen display when operating.

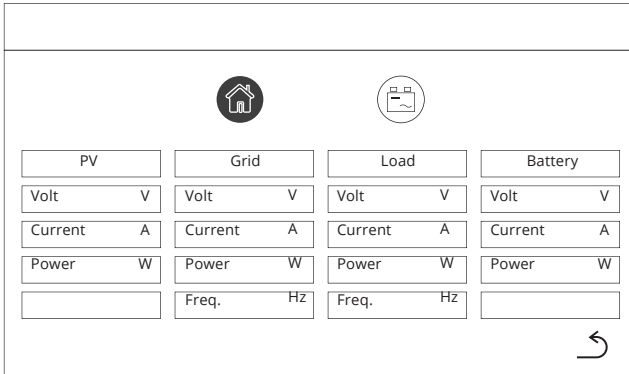

This screen is suitable for 6.2KS models.

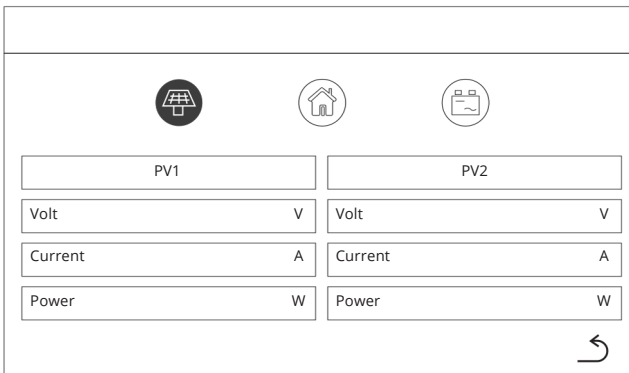

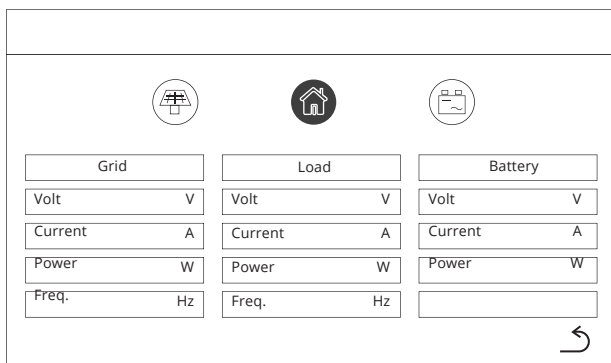

This screen is suitable for 8-12KS models.

### 6.3.2 System Info Page

This page shows the Work Mode, Batt. Type and other system information.

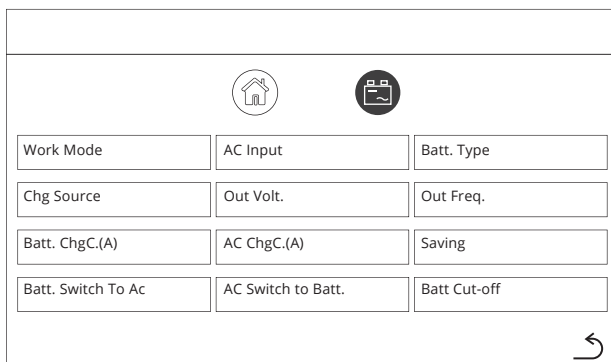

This screen is suitable for 6.2KS models.

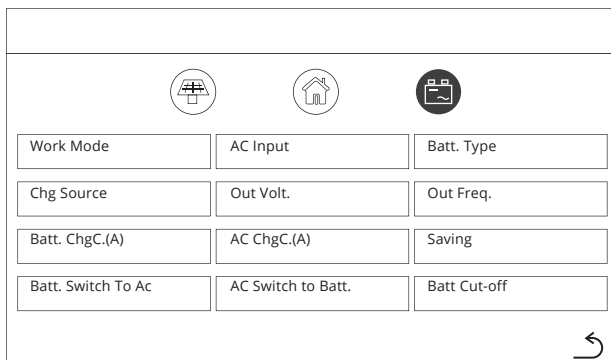

This screen is suitable for 8-12KS models.

## 6.4 Fault Page

This page  shows the real-time fault alarm and fault history of the system.

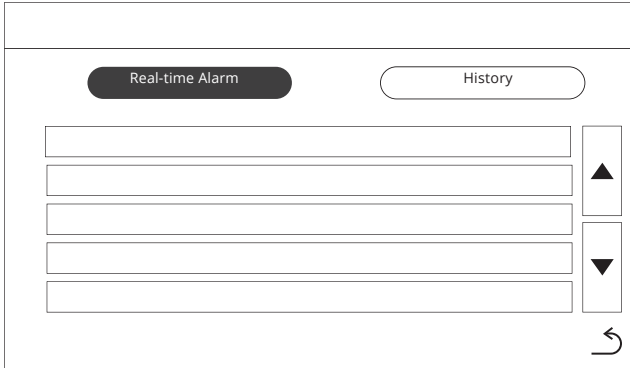

## 6.5 Statistics Page

These two pages ⚡ show statistics info of Grid, Battery, PV and Load.

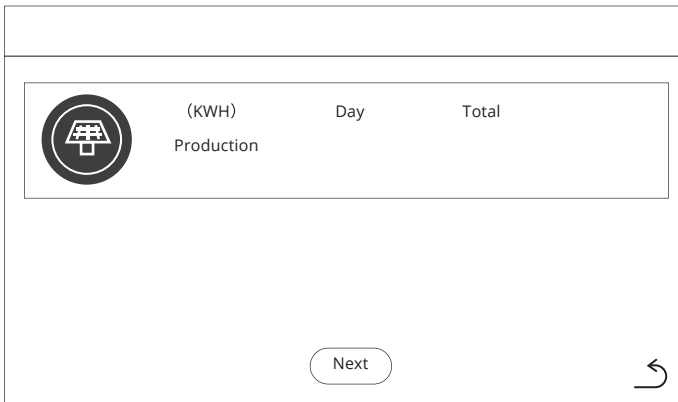

## 6.6 Setting Page

### 6.6.1 Brightness Setting Page

This page ⚙️ shows the brightness setting and screen off time setting. The value range is shown as below:

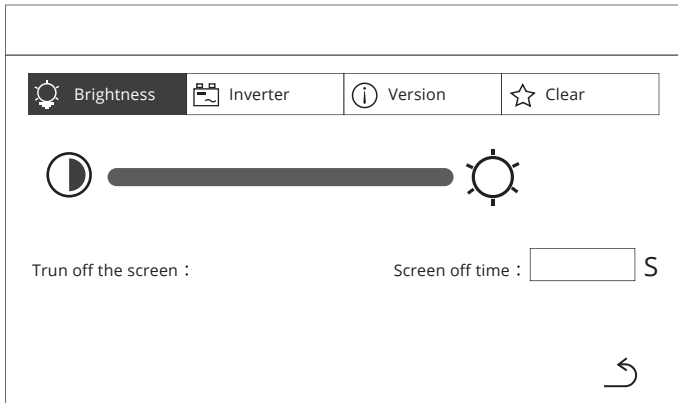

Item	Description	Range
Brightness	the brightness of screen	Min - Max
Screen off time	the time to turn off the screen	5 - 500 s
Turn off the screen	the switch to turn off the screen	ON/OFF

### 6.6.2 Inverter Setting Page

This page needs a password. The default password is "\*\*\*\*\*". Installer can change it in this menu.



### 6.6.2.1 Titan-6.2KS System Setting Page

This page shows the AC Input setting, Out Voltage setting, Out Frequency setting, Parallel setting, Date and Time setting.

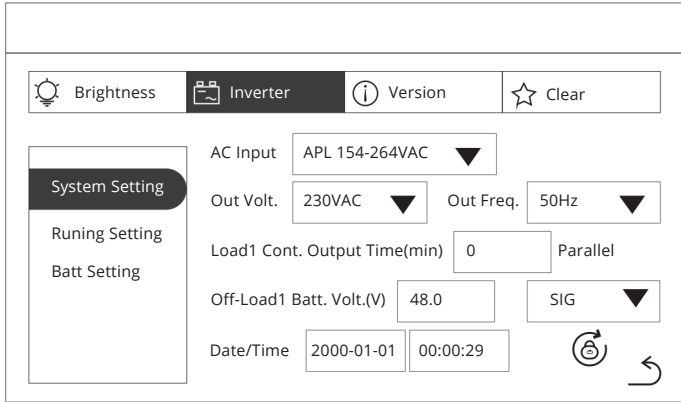

The value range is shown as below:

Item	Description	Default Setting	Range
AC Input	AC input voltage range	APL	APL 154~264Vac
			UPS 185~264Vac
Out Vol.	Output Voltage setting	230V	208V
			220V
			230V
			240V
Out Freq.	Output Frequency setting	50Hz	50Hz   60Hz
Parallel	Parallel setting: SIG: single mode. PAR: parallel mode. 3P1: R-phase mode. 3P2: T-phase mode. 3P3: S-phase mode.	SIG	SIG
			PAR
			3P1
			3P2
			3P3
Date	Date	-	20000101 - 20991231
Time	Time	-	000000 - 235959
Password	Reset the password	*****	10000 - 65535

### 6.6.2.2 Titan-8-12KS System Setting Page

This page shows the AC Input setting, Out Voltage setting, Out Frequency setting, Parallel setting, Date and Time setting.

The value range is shown as below:

Item	Description	Default Setting	Range
AC Input	AC input voltage range	APL	APL 154~264Vac UPS 185~264Vac
Out Vol.	Output Voltage setting	230V	208V 220V 230V 240V
Out Freq.	Output Frequency setting	50Hz	50Hz   60Hz
Parallel	Indep PAR: parallel mode.	Indep PAR (ES)	Indep PAR
Load1 Cont. Output Time(min)	Second output relay time control: the second output is not turned on by default, the second output is turned on after setting the time, and the second output is turned off after reaching the time point.	0	0~890 (5-minute scale)
Off-Load1 Batt.Volt.(V)	Off-Load1 Batt.Volt. = 45.0V, it means when the battery voltage is lower than the 45.0v, the 2nd outout will be cut-off. The restore value is 45V+4V=49.0V. When the working mode switches to PV or Grid, the 2nd output will restore, even when the battery voltage is lower than Off-Load1 Batt.Volt. value.	48	44~60V
Date	Date	-	20000101 - 20991231
Time	Time	-	000000 - 235959
Password	Reset the password	*****	10000 - 65535



**Note!**

- The "Date" should be set with 8 numbers. First 4 numbers are "year". Second 2 numbers are "Month". Last 2 numbers are "Day".  
"20000101" means January 1st, 2000.
- The "Time" should be set with 6 numbers. First 2 numbers are "hour". Second 2 numbers are "minute". Last 2 numbers are "second".  
"120101" means 12:01:01.

**6.6.2.3 Titan-6.2KS Runing Setting Page**

This page shows the Work mode setting, Charge Source setting, Buzzer setting, Energy-Saving setting and Bypass setting.

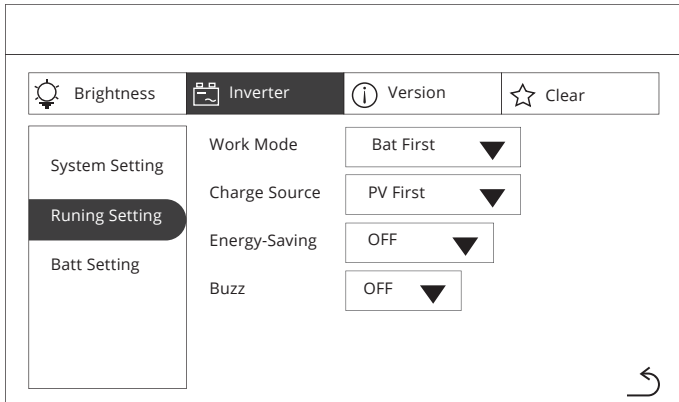

The value range is shown as below:

Item	Description	Default Setting	Range
Work Mode	Output priority setting: Bat First: PV first, Battery second, Grid third output. Pv First: PV priority output. Uti Firs: Grid priority output.	Bat First	Bat First
			Pv First
			Uti First
Charge Source	Charging priority setting: Pv First: PV charging priority. Pv&Uti: PV and Grid are charged at the same time. Pv Only: Only PV charging.	PV First	Pv First
			Pv&Uti
			Pv Only

Energy-Saving	Power Save setting: ON: In battery mode, if the load is lower than 25W, the system will temporarily stop the output. If the load is higher than 35W, the system will resume continuous normal output. OFF: Continuous output regardless of load.	OFF	ON
			OFF
Buzz	Buzzer setting: ON: the buzzer does not sound under any circumstances, such as alarms, faults, etc. OFF: the function is not turned on.	OFF	ON
			OFF

#### 6.6.2.4 Titan-8-12KS Runing Setting Page

This page shows the Work mode setting, Charge Source setting, Buzzer setting, Energy-Saving setting and Bypass setting.

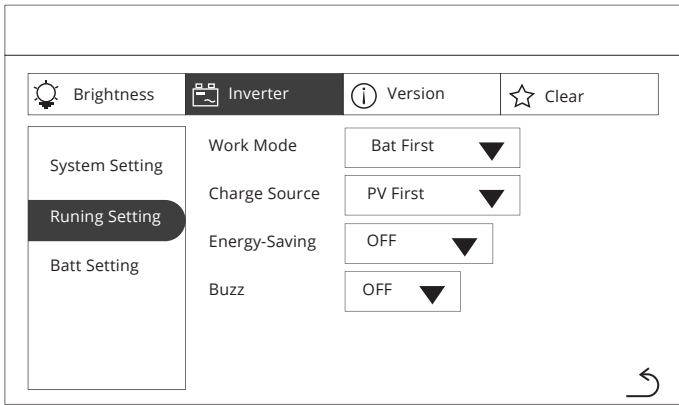

The value range is shown as below:

Item	Description	Default Setting	Range
Work Mode	Output priority setting: Bat First: PV first, Battery second, Grid third output. Pv First: PV priority output. Uti Firs: Grid priority output.	Bat First	Bat First
			Pv First
			Uti First
Charge Source	Charging priority setting: Pv First: PV charging priority. Pv&Uti: PV and Grid are charged at the same time. Pv Only: Only PV charging.	PV First	Pv First
			Pv&Uti
			Pv Only

Energy-Saving	Power Save setting: ON: In battery mode, if the load is lower than 25W, the system will temporarily stop the output. If the load is higher than 35W, the system will resume continuous normal output. OFF: Continuous output regardless of load.	OFF	ON
			OFF
Buzz	Buzzer setting: ON: the buzzer does not sound under any circumstances, such as alarms, faults, etc. OFF: the function is not turned on.	OFF	ON
			OFF

### 6.6.2.5 Titan-6.2KS/Titan-8-12KS Batt Setting Page

This page shows the battery type setting, battery max charge current setting, AC charge current setting.

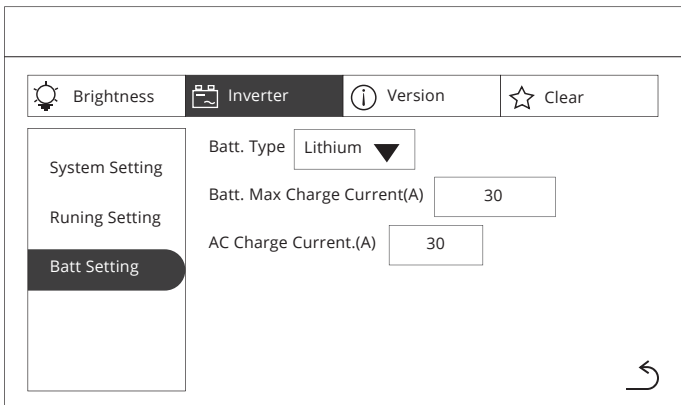

The value range is shown as below:

Item	Description	Default Setting	Range
Batt Type	Battery Type: Lead-acid: lead-acid battery. Lithium: lithium battery. USE2: customer setting type.	Lithium	Lead-acid Lithium USE2
Batt. Max Charge Current	The maximum PV and Gird charging current.(Different models have different charging ranges)	60A	0~100A 0~150A 0~150A
AC Charge current	The maximum Gird charging current.(Different models have different charging ranges)	30A	0~80A 0~120A 0~150A

**Note!**

- The "Batt Type" should be set as "Lithium". Don't choose others during the installation.

After selecting the lithium battery:

The screenshot shows a settings menu with a sidebar on the left containing 'System Setting', 'Runing Setting', and 'Batt Setting' (which is highlighted). The main area displays three settings:

- Batt. Switch to AC SOC(%) with a value of 30
- AC Switch to Batt. SOC(%) with a value of 65
- Batt. Cutoff SOC(%) with a value of 20

At the top of the settings area, there are tabs for 'Brightness', 'Inverter', 'Version', and 'Clear'. A back arrow is visible in the bottom right corner of the settings window.

Item	Description	Default Setting	Range
Batt. Switch to AC SOC (%)	Work mode selection Bat First: Switch to gird mode only when the SOC is above the set point.	30%	10~90%
AC Switch to Batt. SOC (%)	Work mode selection Bat First: Switch to battery mode only when the SOC is above the set point.	65%	10~100%
Batt. Cutoff SOC (%)	When the SOC of lithium battery reaches the set value in battery mode, the power will be turned off and the alarm fault code 103.	20%	5~50%

**Note!**

- The AC Switch to Batt. SOC needs to be higher than The Batt. Switch to AC SOC.
- The fault code 103 will be cleared when the SOC returns to the cutoff SOC + 5%. When the standby is on, the SOC of lithium battery reaches the cutoff SOC + 10% before it can be transferred to battery mode, and the alarm fault code 103 will be alarmed when the SOC does not reach the cutoff SOC + 10%. When the function is turned on, the fault code 103 is warned when the lithium battery SOC reaches the cutoff SOC + 5%, and clears warning 103 when it returns to the cutoff SOC + 10%.

After selecting the lead-acid battery/USE2 setting:

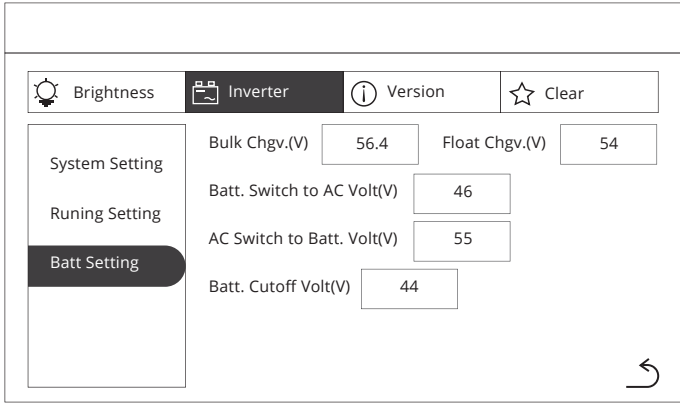

The value range is shown as below:

Item	Description	Default Setting	Range
Bulk ChgV. (V)	Constant voltage point setting Lead-acid battery cannot be set.	56.4V	48-62V
Float ChgV. (V)	Float voltage point setting	54V	48-62V
Batt. Switch to AC Volt (V)	Switch to Gird mode when the battery voltage reaches the set value in battery mode.	46V	44-50V
AC Switch to Batt. Volt (V)	Switch to battery mode when the battery voltage reaches the set value in battery mode.	55V	48-58V
Batt. Cutoff Volt (V)	When the battery voltage reaches the set value in battery mode, the power will be turned off.	44V	40-48V

	<p><b>Note!</b></p> <ul style="list-style-type: none"> <li>● The AC Switch to Batt. Volt needs to be higher than The Batt. Switch to AC Volt.</li> </ul>
---	--

### 6.6.3 Version Page

This page shows the version and serial number of the system.

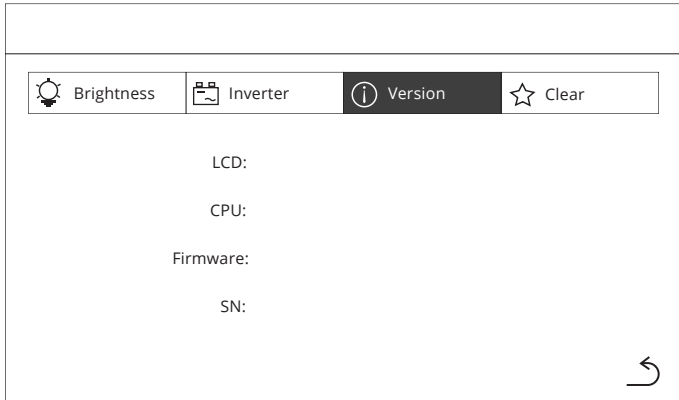

### 6.6.4 Clear Page

This page needs a password. The default password is "\*\*\*\*\*". Installer can change it in the setting.

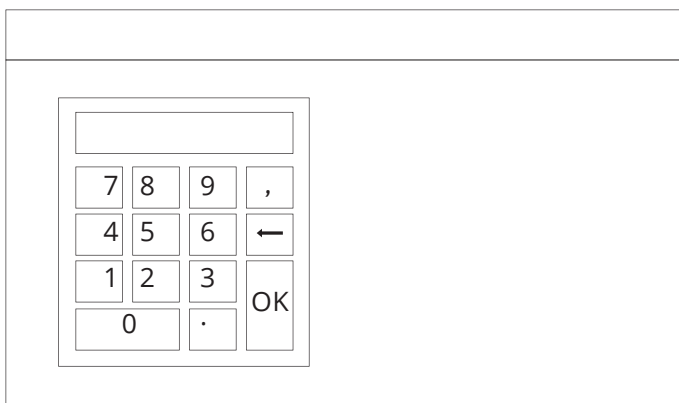

This page shows the clear options of the storage.

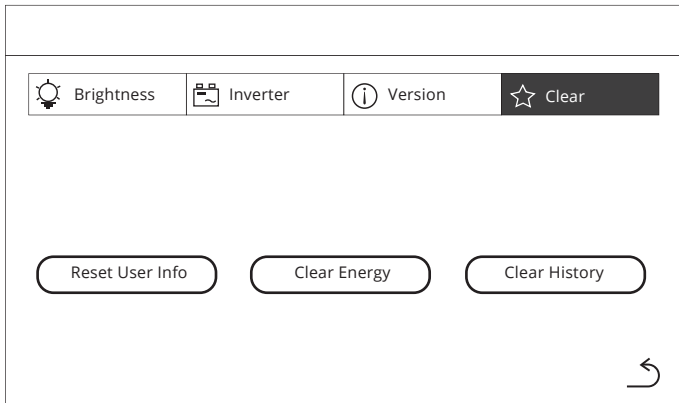

	<p><b>Note!</b></p> <ul style="list-style-type: none"><li>● All the data can not be restored after the clearance!</li></ul>
---	---

## 6.7 Start up the System

The system shall be turned on in the correct sequence as follows:

- 1) Turn on the BAT Breaker.
- 2) Press Inverter button.
- 3) Wait for 30s and observe the LCD to check the running status.
- 4) If the system is running normal, please do commission configuration.

If the system is not work normally, please re-check the wiring and setting until the system runs normal.

- 5) Set the details on the local screen.

## 6.8 Shut Down the System

System shall be turned OFF in the correct sequence as follows:

- 1) Press Inverter button.
- 2) Turn off the BAT Breaker.

## 7 Failure Codes and Countermeasures

001	Bus Up Volt Fail	Fault	BUS Voltage Startup Fault	Recoverable after reboot. If it is not recoverable, please contact us.
002	Bus volt High	Fault	BUS Voltage High Fault	Recoverable after reboot. If it is not recoverable, please contact us.
003	Bus Volt Low	Fault	BUS Voltage Low Fault	Recoverable after reboot. If it is not recoverable, please contact us.
004	DCDC Abnormality	Fault	DC/DC Circuit Abnormality	Recoverable after reboot. If it is not recoverable, please contact us.
005	Over Temperature	Fault	High Inverter Temperature	After six occurrences, a reboot is required to recover. If it is not recoverable, please contact us.
006	Batt. Volt Low	Fault	Low Battery Voltage	Reboot after charging the battery/ Reboot after setting battery low voltage cutoff point. If it is not recoverable, please contact us.
007	Bus Input Up Fail	Fault	Bus Soft Start Reach The Set Voltage.	Recoverable after reboot. If it is not recoverable, please contact us.
008	Bus Short	Fault	Bus Short Faults.	Recoverable after reboot. If it is not recoverable, please contact us.
009	Inv. Softstart Fail	Fault	Inverter Soft Start Failure	Recoverable after reboot. If it is not recoverable, please contact us.
010	Inv. Volt High	Fault	Inverter High Voltage	Recoverable after reboot. If it is not recoverable, please contact us.
011	Inv. Volt Low	Fault	Inverter Low Voltage	Recoverable after reboot. If it is not recoverable, please contact us.
012	Inv. Short	Fault	Inverter Short Circuit	Recoverable after reboot. If it is not recoverable, please contact us.
013	Negative Power Fail	Fault	Output Negative Power.	Recoverable after reboot. If it is not recoverable, please contact us.

014	Over-load	Fault	Loads Out of Specification.	After six occurrences, a reboot is required to recover. If it is not recoverable, please contact us.
015	Model Fail	Fault	Model Fail Fault	Recoverable after reboot. If it is not recoverable, please contact us.
016	No Boot Fail	Fault	No bootloader.	Recoverable after reboot. If it is not recoverable, please contact us.
017	Flash Down Fail	Fault	Flash Down Fail Fault	Recoverable after reboot. If it is not recoverable, please contact us.
018	PV Over Current	Fault	PV Input Over Current.	Check the PV input and restart, please do not exceed the specification power. If it is not recoverable, please contact us.
019	Parallel sn same Fault	Fault	The Parallel Serial Number is The Same.	Recoverable after reboot. If it is not recoverable, please contact us.
020	Parallel CANComm. Fail	Fault	Parallel CANComm Fail	Recoverable after reboot. If it is not recoverable, please contact us.
021	Parallel Bat volt Diff.	Fault	Excessive Voltage Difference Between Parallel Batteries.	Check mains voltage. If it is not recoverable, please contact us.
022	Parallel Grid volt Diff.	Fault	Excessive Difference in Parallel Mains Voltage.	Check mains voltage. If it is not recoverable, please contact us.
023	Parallel Grid Freq. Diff.	Fault	Excessive Difference in Parallel Utility Frequency.	Check the mains input frequency. If it is not recoverable, please contact us.
024	Parallel Output Set Error	Fault	Parallel Output Setting Error.	Check the parallel setting. If it is not recoverable, please contact us.
025	Parallel Lost Synchronous	Fault	Parallel Loss of Synchronization.	Check parallel wiring. If it is not recoverable, please contact us.
026	BMS Fail	Fault	BMS Communication Failure.	Recoverable after reboot. If it is not recoverable, please contact us.

095	Device Comm. Fail	Alarm	Display Screen Communication Alarm	Recoverable after reboot. If it is not recoverable, please contact us.
100	Batt. Volt Low	Alarm	The Battery Low Voltage Point.	Reboot after charging the battery/ Reboot after setting battery low voltage cutoff point. If it is not recoverable, please contact us.
101	Batt. Disconnected	Alarm	Battery Not Connected.	Ensure reboot with normal battery output. If it is not recoverable, please contact us
102	Charge short	Alarm	Charge Short Alarm	Recoverable after reboot. If it is not recoverable, please contact us.
103	SOC Low shut Down	Alarm	The Battery Low SOC Point.	Reboot after charging the battery/Reboot after setting battery low SOC cutoff point. If it is not recoverable, please contact us.
104	SOC Low Alarm	Alarm	The Battery Low SOC+5% Point.	Reboot after charging the battery/Reboot after setting battery low SOC cutoff point. If it is not recoverable, please contact us.
105	Batt. start Fail	Alarm	The Battery Start Alarm	Recoverable after reboot. If it is not recoverable, please contact us.
106	BMS Loss	Alarm	BMS Loss Alarm	Check if the battery communication and inverter are in contact
107	Charge volt High	Alarm	Battery Voltage is Higher Than The Set Value.	Recoverable after reboot. If it is not recoverable, please contact us.
109	Temperature High	Alarm	The Temperature Sensor of PFC or INV is Higher Than The Set Value.	The temperature sensor of PFC or INV is lower than the set value. If it is not recoverable, please contact us
111	Fan Lock	Alarm	Fan Speed Signal Not Detected	Recoverable after reboot. If it is not recoverable, please contact us.
112	Low Power Disc.	Alarm	Low Power Disc Alarm	Recoverable after reboot. If it is not recoverable, please contact us.

113	EEPROM Fail	Alarm	EEPROM Fail Alarm	Recoverable after reboot. If it is not recoverable, please contact us.
114	Batt Volt Low Shut Down	Alarm	The Battery Low Volt Point.	Reboot after charging the battery/Reboot after setting battery low SOC cutoff point. If it is not recoverable, please contact us.
115	Gen waveform Fail	Alarm	Abnormal Generator Fluctuations.	Check the generator. Check the battery level. If it is not recoverable, please contact us.
158	Parallel Grid volt Diff.	Alarm	Excessive Difference in Parallel Mains Voltage.	Check mains voltage. If it is not recoverable, please contact us.
162	Parallel version Diff	Alarm	The Parallel Version Different	Recoverable after reboot. If it is not recoverable, please contact us.
163	Parallel Com. Fail	Alarm	Parallel Com Alarm	Check the parallel communication cable. If it is not recoverable, please contact us.
164	Parallel Lost synchronous	Alarm	Parallel Loss of Synchronization.	Check parallel wiring. If it is not recoverable, please contact us.
165	Parallel Set Error	Alarm	Parallel Setting Error.	Check the parallel setting. If it is not recoverable, please contact us.

## 8 System Maintenance

### 8.1 Storage

After purchasing the system, please store it with following instructions:

- ① Please store it in a dry and ventilated environment, keep it away from heat sources.
- ② Please keep it in an environment with storage temperature as  $-15\text{ }^{\circ}\text{C} \sim 60\text{ }^{\circ}\text{C}$ , humidity  $<85\%$  RH.
- ③ For long-term storage ( $>3$  months), please put it in an environment with a temperature of  $18\text{ }^{\circ}\text{C}$  to  $28\text{ }^{\circ}\text{C}$  and a humidity of  $< 85\%$  RH.
- ④ The system should be stored in accordance with the storage requirements mentioned above, and the system should be installed within 6 months since delivered from the factory. Failure to install beyond 6 months is not covered by the manufacturer's warranty.
- ⑤ Failure to complete the installation within 6 months from the factory is subject to recharge operation. Consult the dealer or manufacturer for details of the operation.

### 8.3 Cleanliness

Clean the enclosure lid, LCD of the inverter with moistened cloth with clear water only. Do not use any cleaning agents as it may damage the components.

