



Take your power with you 

ZEUS HYBRID SOLAR INVERTER

Quick Installation Guide







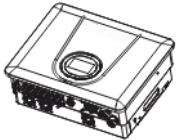
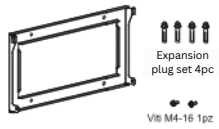
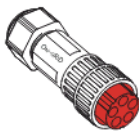
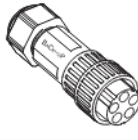

Please visit our website www.srportables.com to register your product.

Note: Please scan the QR code to view the user manual before using the product and place it in a safe and easily accessible place. Improper use may lead to risks and accidents, so you must operate carefully by following all instructions. If you have any questions or uncertainties, please consult our technicians or after-sales service team immediately.

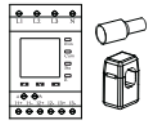
1. Installation

A. Check the Packing List

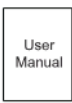
 Inverter 1 pc	 Expansion plug set 4pc Viti M4-16 1pz	 Grid Connector Set (Red) 1pc	 Back-up Connector Set (Black) 1pc
 Zeus 6kt photovoltaic terminal 2 pairs / Zeus 20kt 4 pairs	 Zeus 6kt battery terminal 1 pair / Zeus 20kt 2 pairs	 Meter with 3 CTs 1pc	 COM Connector Set 1pc
 Monitoring device 1pc	 10m communication cable 1pc 3m battery communication cable Zeus 6kt 1pc / Zeus 20kt 2pcs	 PE terminals 1pc	 User Manual User Guide 2 pieces

B. Installation location

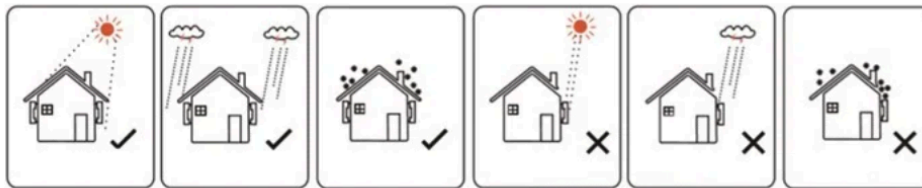

C. Installation Space

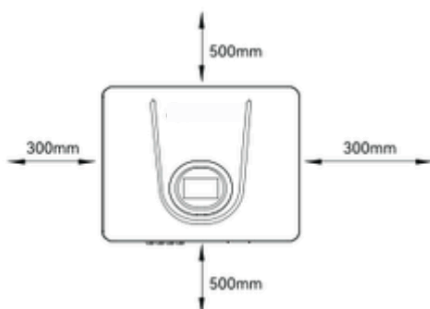

D. Installation Angle

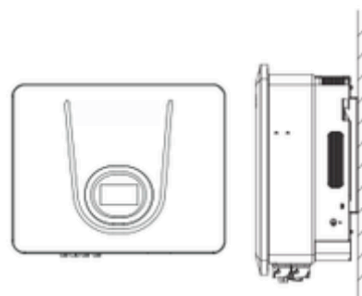

E. Mark the Position and Drill the Holes

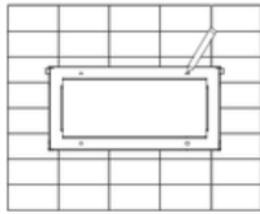

F. Fixed Wall Bracket

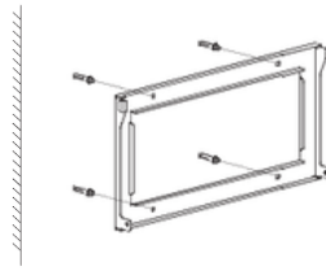

G. Inverter Assembly

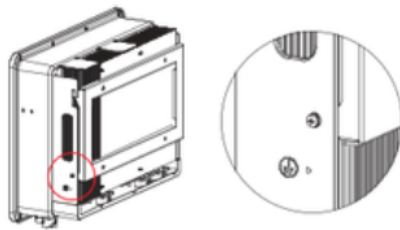

H. Connecting the Ground Terminal



2. Electrical connection

A. Select the Appropriate Cable

Types of Cables	Cable Requirements	
	External Diameter	Conductor's Section
AC cable	13.0-18.0 mm	2.5-10.0 mm ²
Photovoltaic cable	5.9-8.8 mm	4 mm ²
Battery Power Cable	5.0-8.0 mm	6-10 mm ²

AC cable: The grid side uses a five-core cable (L1, L2, L3, N and PE). The backup side uses a four-core cable (L1, L2, L3, N).

AC connector: Distinguish the grid and backup connector, the grid connector is red and the backup connector is black.

Battery power cable: If the conductor core of the battery cable is too small, which may cause poor contact between the terminal and the cable, please use the cable specified in the table above or contact SR Portables to purchase terminals of other specifications.

B. Electrical Diagram

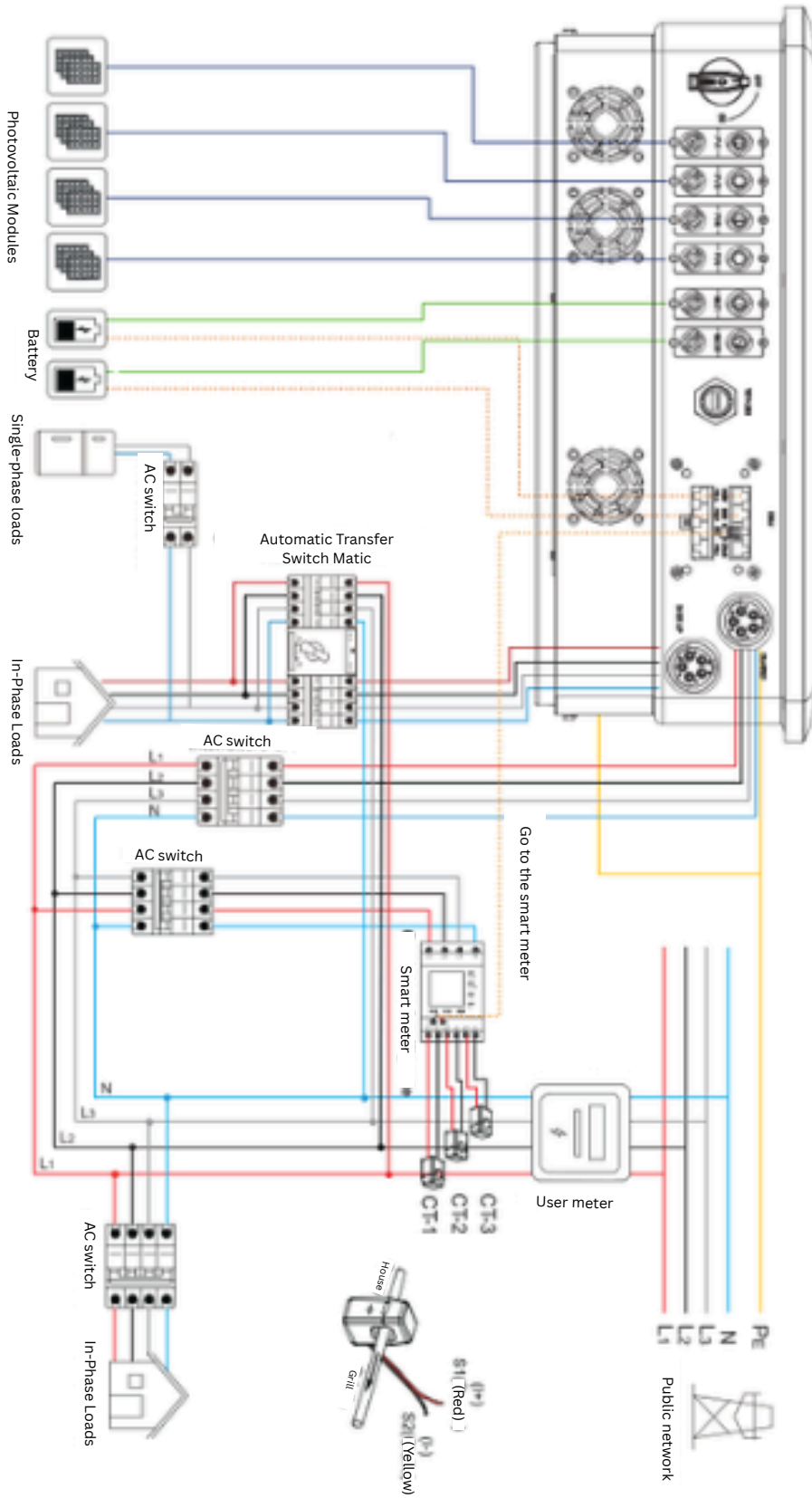

C. AC connection

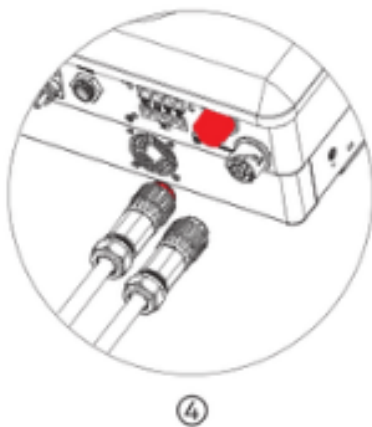
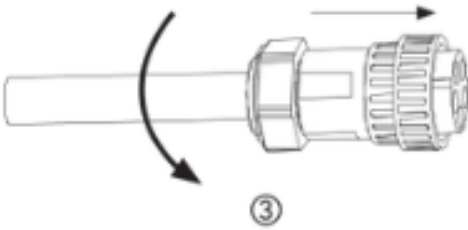
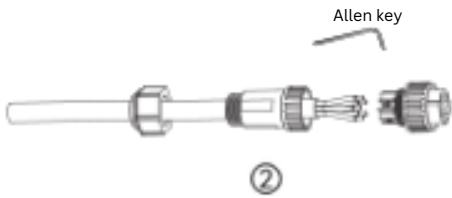
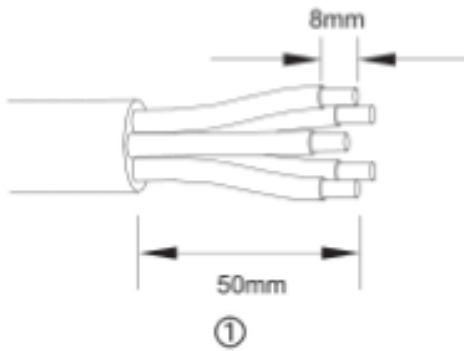

D. Installing the Monitoring Device

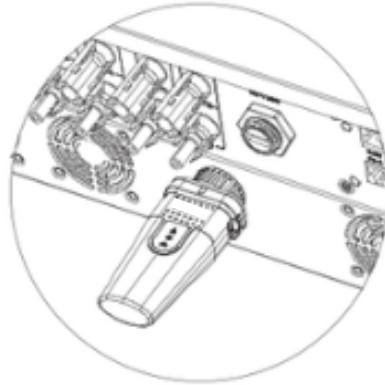

E. Meter and CT connection

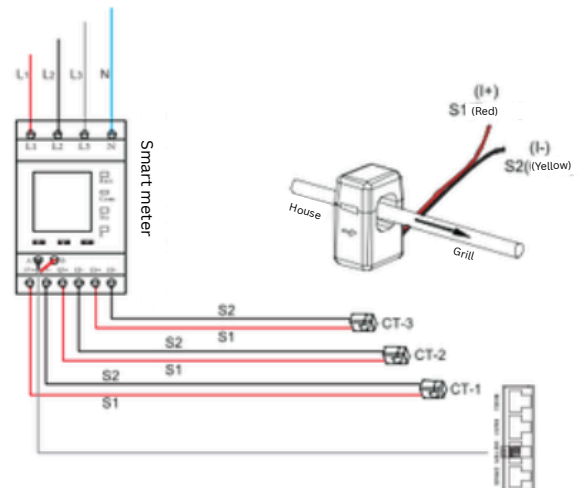
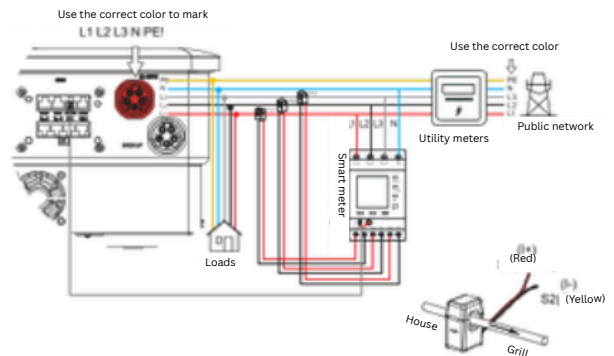

Definition of Meter Terminals

No.	Definition	Function
I1+	L1-S1	To detect the current and direction of the CT
I1-	L1-S2	
I2+	L2-S1	
I2-	L2-S2	
I3+	L3-S1	
I3-	L3-S2	
L1	L1	L1/L2/L3/N connect to the network to detect the voltage of the electrical network
L2	L2	
L3	L3	
N	N	
A	RS485	Communicate with the inverter
B		

F. Communication Connection

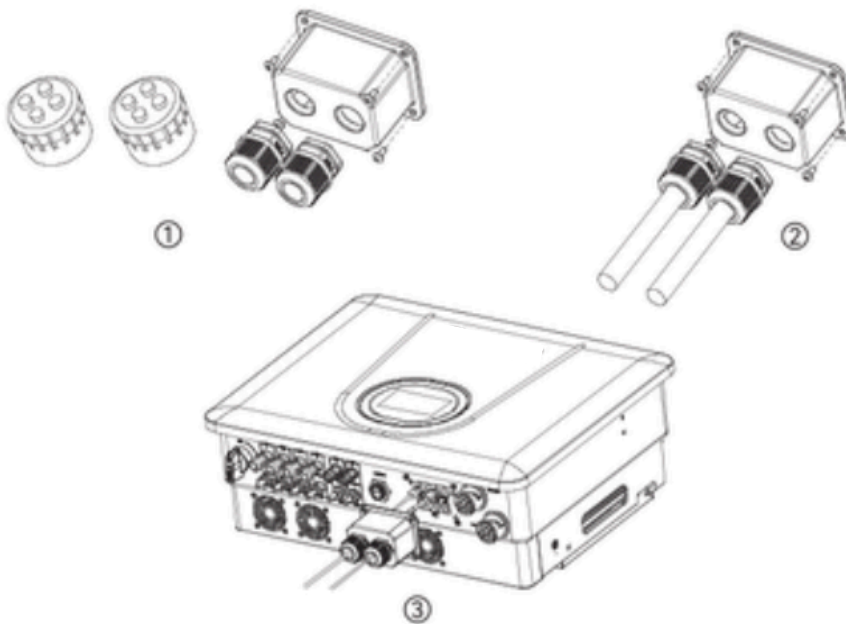

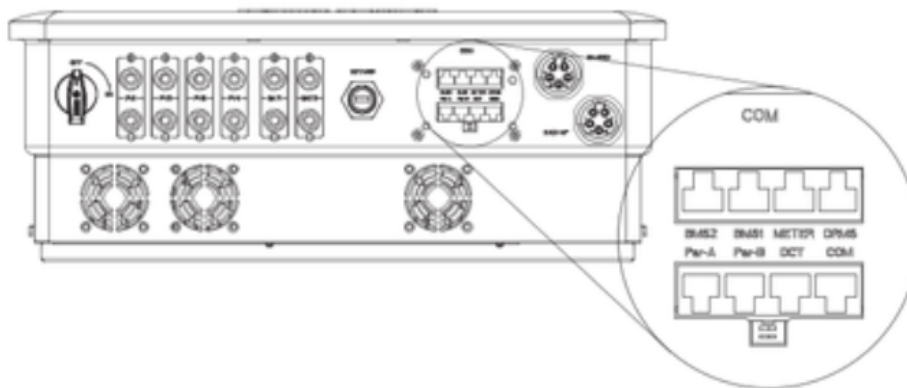

RJ45	Definition	Function
BMS1	CAN1	Communicating with BMS1
BMS2	CAN2	Communicating with BMS2
METER	RS 485	Communicate with meter
DRMS	PIN1-PIN5	DRM for Australia and New Zealand
PAR-A	SYN1-3,CAN,RS 485	Parallel connection of inverters, EMS
PAR-B	SYN1-3,CAN,RS 485	Parallel connection of inverters, EMS
DCT	DCT1/2-DCT3/4	Multifunction relay
COM	DI+,DI-,DI1+~DI4+	Multifunction relay

No.	Color	BMS 1 side	BMS 2 side	Enter if
1	Orange & White	/	/	/
2	Orange	/	/	/
3	Green & White	/	/	RS485_B1
4	Blue	CANH1	CANH2	/
5	Blue & White	CANL1	CANL2	/
6	Green	/	/	RS485_A1
7	Brown & White	/	/	/
8	Brown	/	/	/

Sequence and definition of DRMs RJ45 terminal connection

No.	Color	DRMs side
1	orange & white	DRM1/5
2	orange	DRM2/6
3	green & white	DRM3/7
4	Blue	DRM4/8
5	blue & white	REF D/0
6	Green	COM D/0
7	Brown & white	/
8	Brown	/

RJ45 COM Terminal Connection Sequence and Definition

No.	Color	COM side
1	orange & white	/
2	orange	/
3	green & white	DI1+
4	Blue	DI2+
5	blue & white	DI3+
6	Green	DI4+
7	Brown & white	DI+
8	Brown	DI-

Sequence and definition of DCT RJ45 terminal connection

No.	Color	DCT side
1	orange & white	DCT3
2	orange	
3	green & white	DCT4
4	Blue	
5	blue & white	DCT1
6	Green	
7	Brown & white	DCT2
8	Brown	

Sequence and definition of the PAR RJ45 terminal connection

No.	Color	Par-A side	Par-B side	Function
1	orange & white	SYN1	SYN1	Synchronous signal
2	orange	SYN2	SYN2	
3	green & white	SYN3	SYN3	
4	Blue	GND	GND	
5	blue & white	RS485_A2	RS485_A2	EMS communication
6	Green	RS485_B2	RS485_B2	
7	Brown & white	Par.CANH	Par.CANH	Parallel CAN switching
8	Brown	Par.CANL	Par.CANL	

G. Photovoltaic string connection

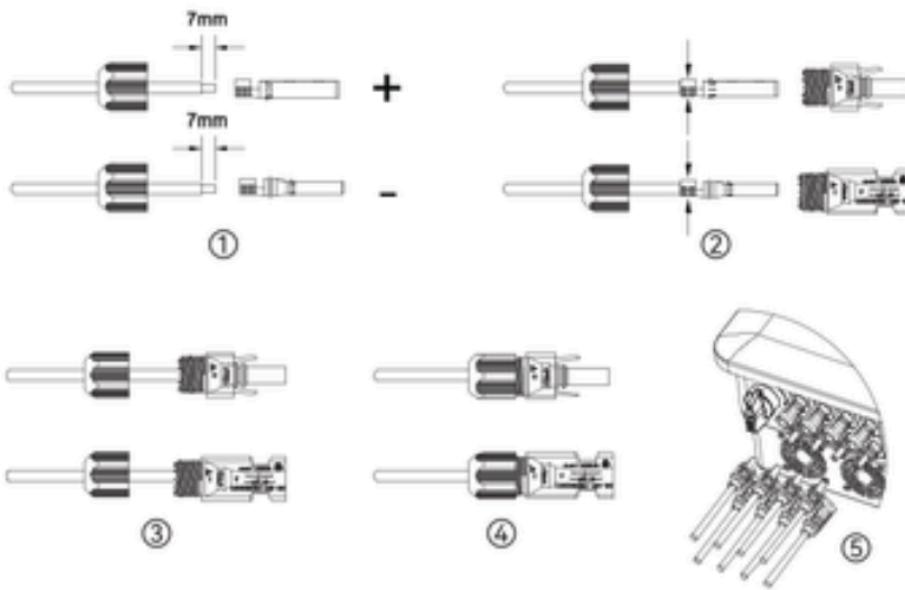

H. Battery connection power cable

