



Take your power with you 

Thor Series

Hybrid Storage Unit





















Please visit our website www.srportables.com to register your product.













1. Installation

1.1 Check Packing List







Hybrid Inverter Package List

 Hybrid Inverter × 1 pcs	 User Manual × 1 pcs	 Monitor Module × 1 pcs	 CT × 1 pcs
 PV+ Input Terminal × 2 pcs Secured Metal Terminals to PV+ Input Power Cables × 2 pcs	 PV- Input Terminal × 2 pcs Secured Metal Terminals to PV- Input Power Cables × 2 pcs	 Waterproof Aviation Male Pin Plug × 1 pcs	 Waterproof Aviation Female Pin Plug × 1 pcs
 Waterproof Terminal × 1 pcs	 Tube Terminal (Red) × 2 pcs	 Tube Terminal (Black) × 2 pcs	 Tube Terminal (Yellow) × 2 pcs
 Fixed Support Rack × 2 pcs	 Round Head Screws M3*5 × 4 pcs	 SEM Screw M4*10 × 4 pcs	 Expansion Screw M6 × 2 pcs
 Allen Wrench D-3mm L Type × 1 pcs	 Qualified Certificate × 1 pcs	 Packing List × 1 pcs	

Storage Battery Package List

 Battery × 1 pcs	 Fixed Support Rack × 2 pcs	 Expansion Screw M6 × 2 pcs	 Round Head Screws M3*5 × 4 pcs
 Right Side Cover × 1 pcs	 Left Side Cover × 1 pcs	 Grounding Cable × 1 pcs	 Qualified Certificate × 1 pcs
 SEM Screw M4*10 × 4 pcs	 Guide Pin × 4 pcs	 Cable Grommet × 8 pcs	 Countersunk Screw × 8 pcs
 Packing List × 1 pcs			

Battery Base Package List

 Battery Base × 1 pcs	 Guide Pin × 4 pcs	 Grounding Cable × 1 pcs	 Qualified Certificate × 1 pcs
 Packing List × 1 pcs		 External Positive Connection Wire × 1 pcs (The Length is Determined According to the Number of Stacked Batteries)	

1.2 Installation Location

Storage unit is cooled by natural wind convection. It is recommended to install in indoors or sheltered areas to avoid direct sunlight, rain and snow.

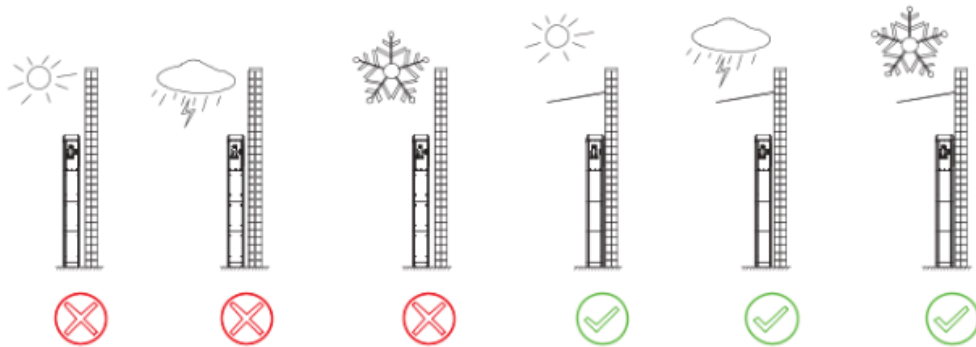

1.3 Installation Space

Need to stay 300mm away from other objects

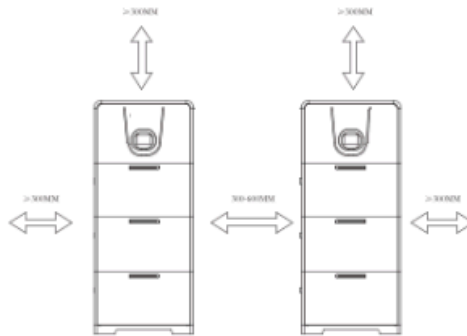

1.4 Preparation

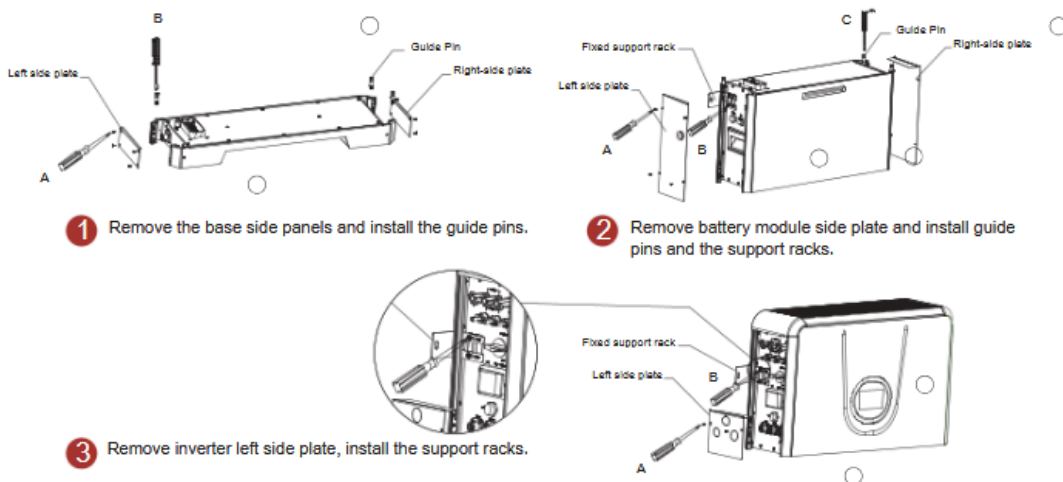

1.5 Installation

1 Fix the base

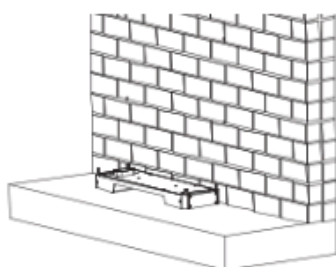

2 Installing the battery module and inverter module in sequence

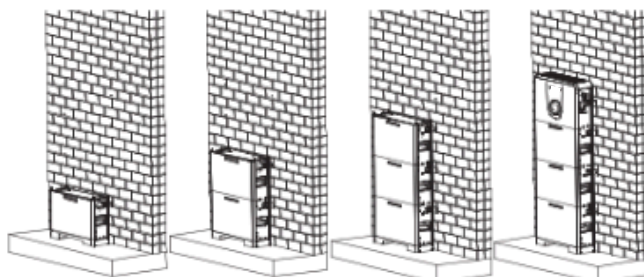

3 Mark the punching position

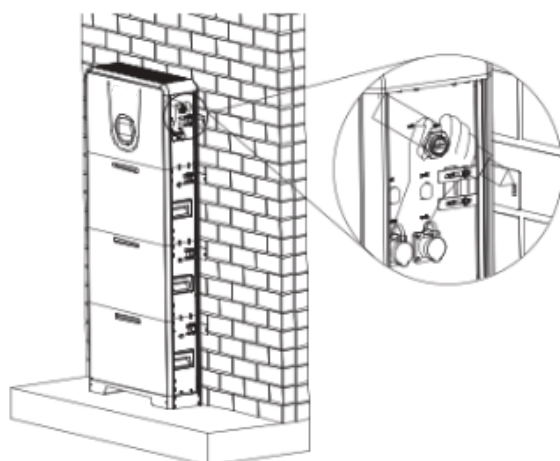

4 Install fixing screws

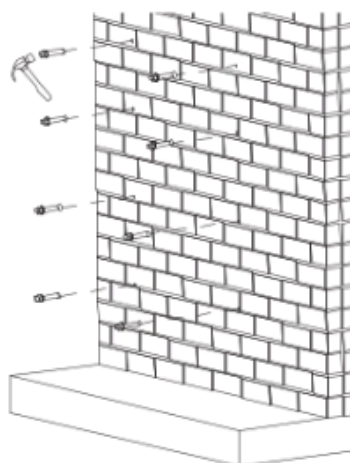

5 Adjusting the distance against the wall

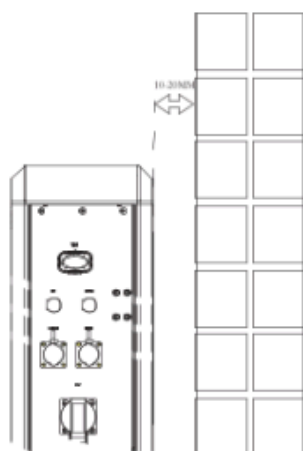

6 Tighten the cascading fixing screws

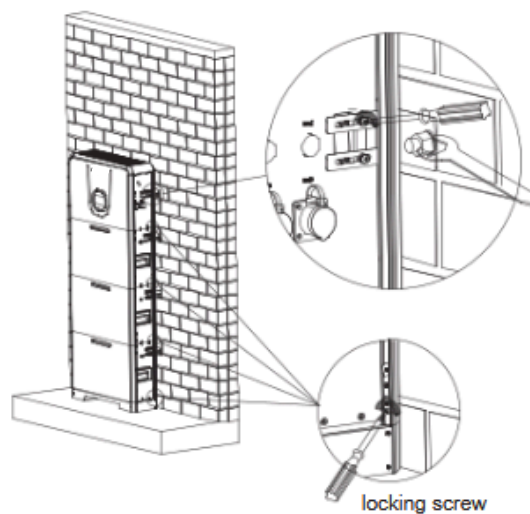

2. Electrical Connection

2.1 Electrical Wiring Diagram

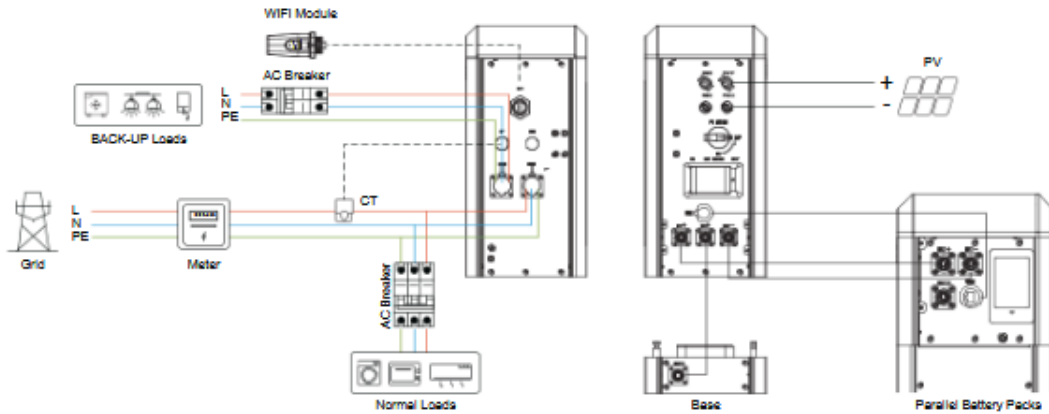

2.2 Battery Wiring

1 Wire harness connect

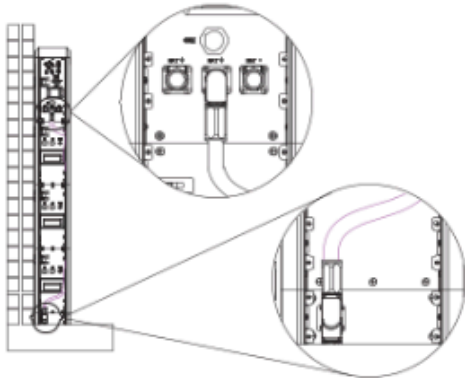

2 Set the DIP switch of each battery

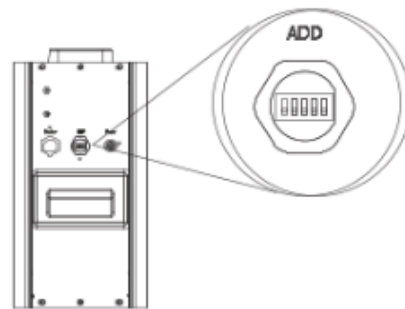

DIP switch configuration can be found below (Batteries 1~8 are counted from top to bottom)

Configuration	Battery (No.1)	Battery (No.2)	Battery (No.3)	Battery (No.4)	Battery (No.5)	Battery (No.6)	Battery (No.7)	Battery (No.8)
1* Inverter 1* Battery		/	/	/	/	/	/	/
1* Inverter 2* Battery			/	/	/	/	/	/
1* Inverter 3* Battery				/	/	/	/	/
1* Inverter 4* Battery					/	/	/	/
1* Inverter 5* Battery						/	/	/
1* Inverter 6* Battery							/	/
1* Inverter 7* Battery								/
1* Inverter 8* Battery								

Note: "□" The white part indicates a dip switch, "■" the black part is blank.
Batteries 1~8 are counted from top to bottom

2.3 Grounding Wire

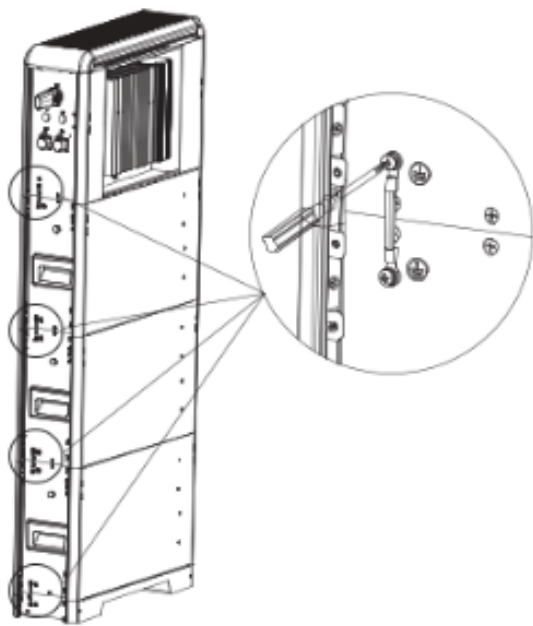

2.4 Side Protection Cover Installation

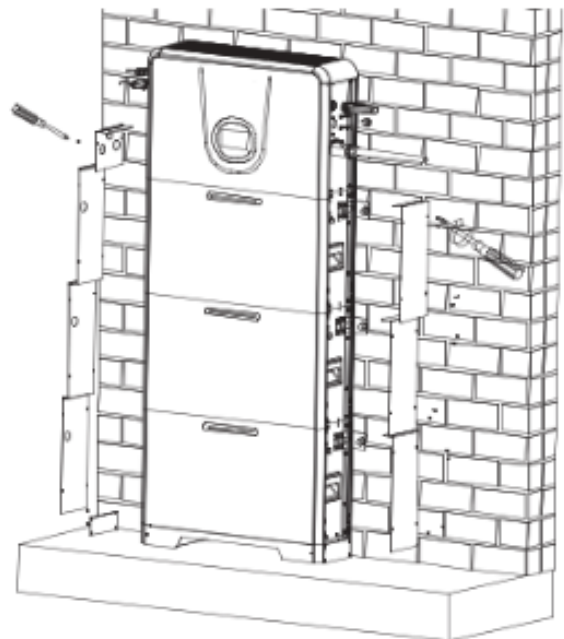

2.5 PV Input Wiring

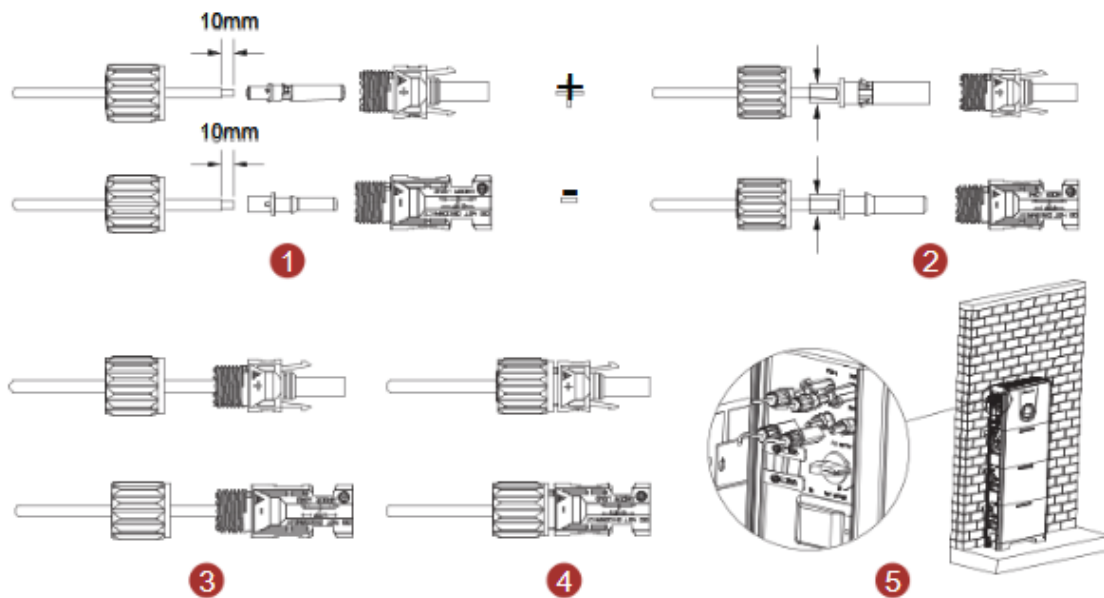

2.6 AC Connection

Cable type	Conductor cross-sectional area (mm ²)	
	Outside diameter (mm ²)	Conductor core section (mm ²)
10 AWG	5.5-8.0	4.0-6.0



1 Peel off the cable insulation sleeve for 16 mm.

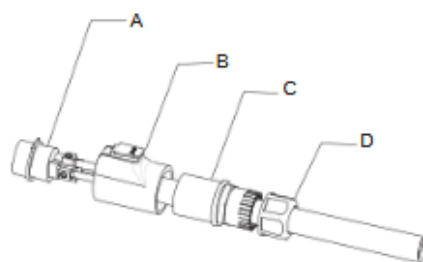

2 Disassemble the plug and pass the cable through the plug part in the order of D-C-B-A.

Color	Number
L	1
N	2
PE	3

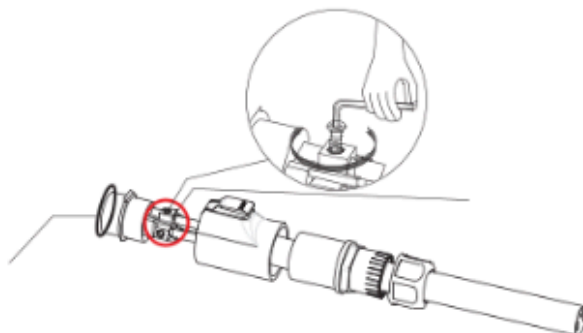

3 Insert the cable into the corresponding terminal block and lock the screw.

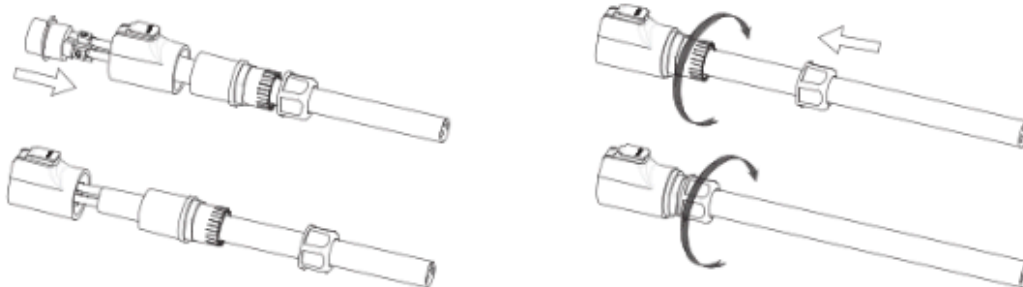

4 Press and hold the "PUSH" button on the shell, push the connected cable seat into the shell.

5 Lock the clamping sleeve and waterproof nut.

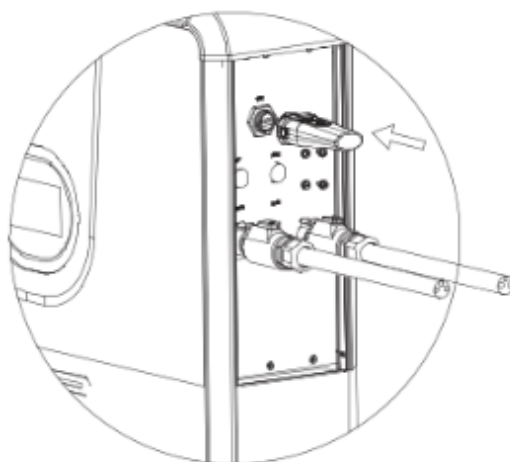

6 Insert the AC cable plugs into the corresponding socket.

7 Insert the WiFi module into the corresponding socket.

2.7 CT Installation

CT solution is offered for sampling data of grid side as standard solution.

Please install CT with instructions as below:

1. Lead the Live line through the CT.
2. Tighten up the CT buckles.
3. Remove the cover of CT port on the right side of inverter.
4. Connect RJ45 plug of the CT to the CT port.

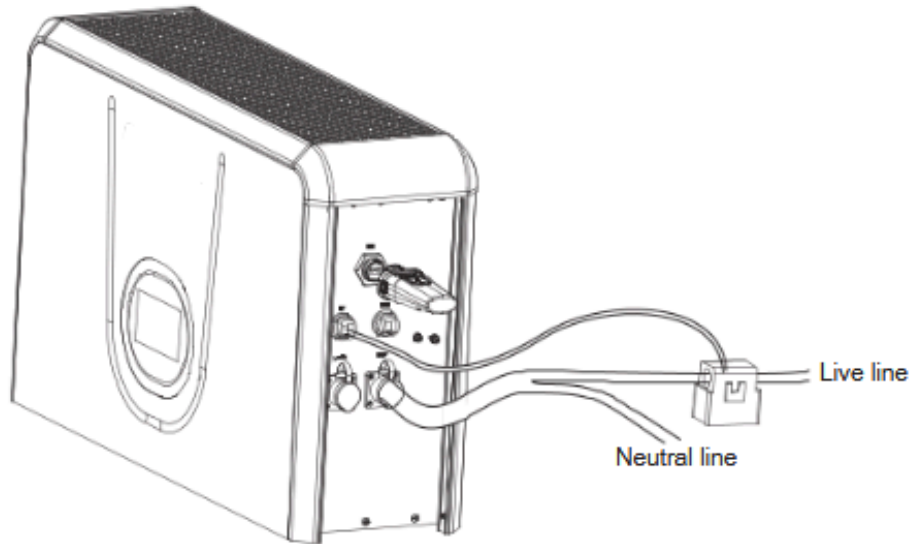

2.8 Battery Expansion

Use the accessory harness to connect two sets of batteries, the battery packs are connected in parallel, BAT + connects to BAT +, BAT - connects to BAT -, COM connects to COM.

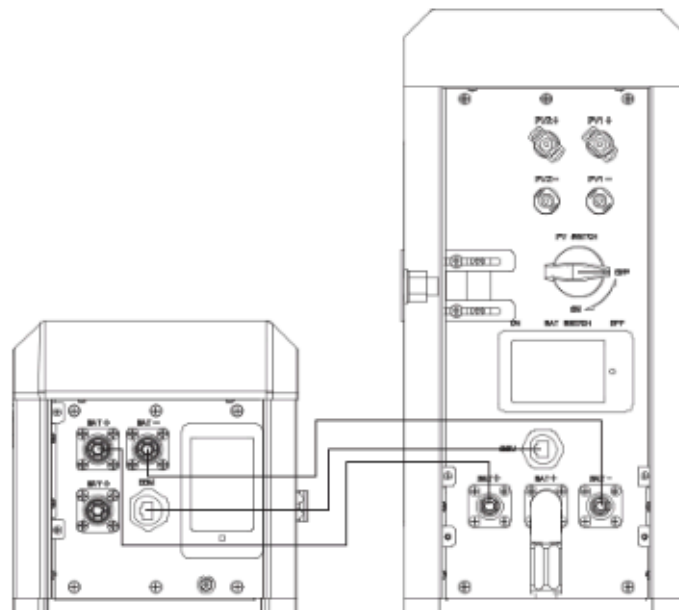

2.9 EV Charging Wiring

If the system needs to be connected to an electric vehicle, it can be charged together with AC power from the grid. Forming a home electric vehicle charging system.

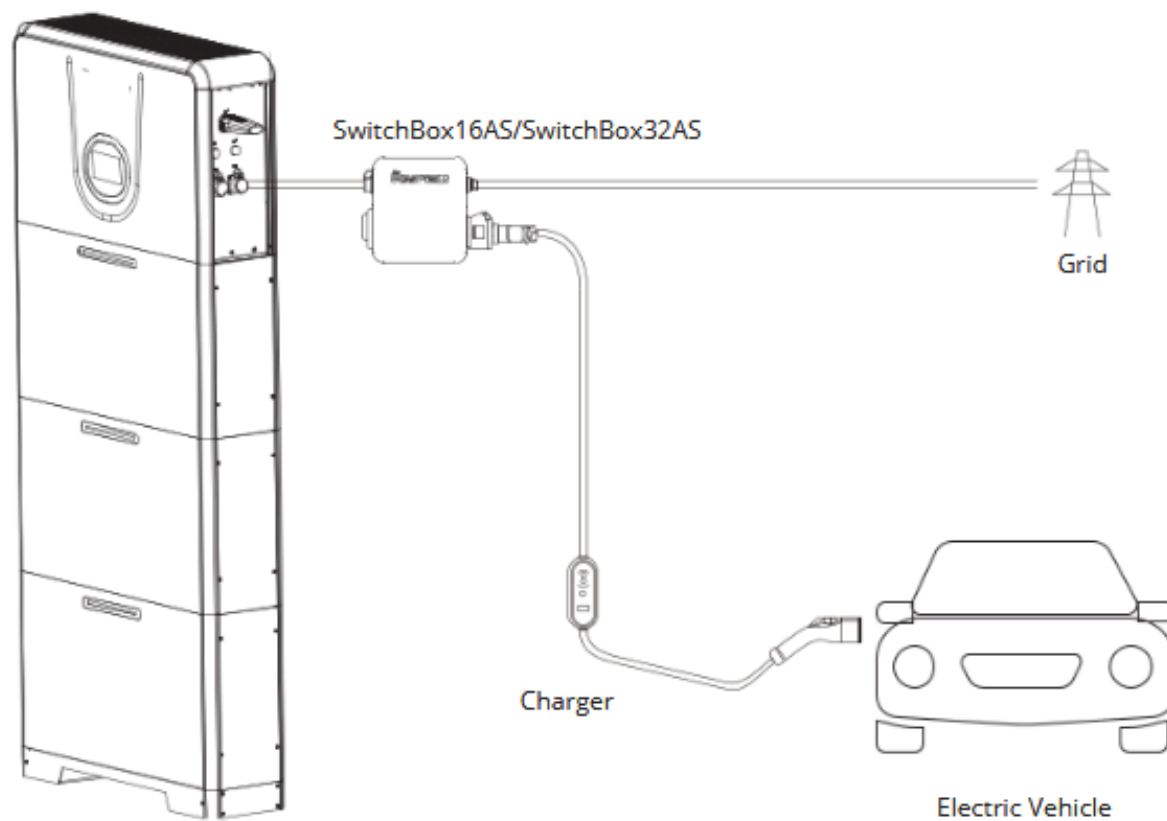

Single-phase all-in-one ESS