



Take your power with you 

Thor Series

Hybrid Storage Unit



Please visit our website www.srportables.com to register your product.

Content

1 Notes on this Manual	3
1.1 Scope	3
1.2 Target Group	3
1.3 Symbols Used	3
2 Safety	4
2.1 Important Safety Instructions	4
2.2 Explanation of Symbols	5
2.3 Emergency situation	6
3 Introduction	8
3.1 Scope of application.....	8
3.2 Product Model Description	9
3.3 Datasheet.....	10
4 Installation Instructions	14
4.1 Safety Tips	14
4.2 Packing List	14
4.3 Determine the installation method and location	17
4.4 Preparations before installation.....	20
4.5 Installation steps for storage unit.....	21
5 Electrical Connections	24
5.1 Electrical Interface Description.....	24
5.1.1 Inverter interface description.....	24
5.1.2 Battery interface description.....	25
5.1.3 Base interface description	25
5.2 System Wiring Schematic.....	26
5.3 Battery Wiring	26
5.3.1 Battery wiring (Battery does not expand).....	27
5.3.2 Grounding wire connection	28
5.3.3 Side protection cover installation.....	28
5.4 PV Input Wiring	29
5.5 Grid/Load Wiring.....	31
5.6 EV Charging wiring.....	34
5.7 Title corresponds to the left side silk screen printing (DCT dry contact function) ...	35
5.8 External current detection.....	35
5.9 External AC Circuit Breaker and Residual Current Device.....	37
5.10 Battery expansion.....	38
6 Local Configuration	39
6.1 Local Interface Introduction.....	39
6.2 Home Page.....	39
6.3 Detail Info Page	40
6.3.1 PV Info Page (only Hybrid).....	40
6.3.2 Grid Info Page	40
6.3.3 Load Info Page.....	41

6.3.4 Battery Info Page.....	41
6.3.5 Inverter Info Page	41
6.4 Fault Page.....	42
6.5 Statistics Page.....	43
6.6 Setting Page.....	43
6.6.1 Brightness Setting Page.....	43
6.6.2 Inverter Setting Page	44
6.6.3 Version Page.....	53
6.6.4 Clear Page	53
6.7 Start up the System.....	54
6.8 Shut Down the System	55
6.9 LED indication	56
6.9.1 Bat LED.....	56
6.9.2 System status indicator.....	56
7 Fault Codes and Common troubleshooting	57
8 Battery Maintenance.....	60
8.1 Transportation.....	60
8.2 Storage.....	60
8.3 Cleanliness	60

1 Notes on this Manual

1.1 Scope

This manual is an integral part of Thor Storage Unit.

Hybrid Inverter		
Thor-3K0L	Thor-3K6L	Thor-4K0L
Thor-4K6L	Thor-5K0L	Thor-6K0L
Thor-8K0L		
Storage Battery		
Thor Bat-1		

This manual describes the assembly, installation, commissioning, maintenance and failure of the product. Please read it carefully before operating.





The manual is only for this batch of shipment.

1.2 Target Group

This manual is for qualified electricians. The tasks described in this manual only can be performed by qualified personnel.



1.3 Symbols Used



The following types of safety instructions and general information appear in this document as described below:

 Danger	Danger! “Danger” indicates a hazardous situation which, if not avoided, will result in death or serious injury.
 Warning	Warning! “Warning” indicates a hazardous situation which, if not avoided, could result in death or serious injury.
 Caution	Caution! “Caution” indicates a hazardous situation which, if not avoided, could result in minor or moderate injury.
 Note	Note! “Note” provides tips that are valuable for the optimal operation of our product.

2 Safety





2.1 Important Safety Instructions





 <p>Danger</p>	<p>Danger!</p> <ul style="list-style-type: none">● Electric shock and high voltage.● Do not expose the storage unit to temperatures in excess of 45°C.● Do not subject the storage unit to any strong force.● Do not touch uninsulated cable termination.● Do not soak the storage unit in water or expose it to moisture environment.● Do not touch the case of the storage unit when it is wet in case of electric shock.● Do not dispose of batteries in fire. The batteries may explode!● Do not place the storage unit near a heat source, such as direct sunlight, a fireplace.● Keep inflammable and explosive dangerous items or flames away from the storage unit.● Do not charge or discharge damaged storage unit.● Before performing any work on the storage unit, please disconnect the storage unit from all voltage sources as described in this document.
 <p>Warning</p>	<p>Warning!</p> <ul style="list-style-type: none">● Installation, repair, recycling, and disposal of storage unit must be performed by qualified personnel in accordance with national and local standards and regulations.● Risks of chemical burn electrolyte or toxic gases.● Do not place heavy objects on the top of the system.● Do not connect any un-dedicated battery pack to Thor storage unit.● If the moisture penetrates the system (e.g., due to casing damage), please do not install or operate the system.● Do not use wet hands to touch the system.● Any behavior to change the functionality of the product without permission will cause fatal injury to the operator, third parties, and equipment. Thor is not responsible for these losses and warranty claims.● To ensure property and personal safety, the batteries and inverter shall be well grounded.

 Caution	<p>Caution!</p> <ul style="list-style-type: none"> ● Do not modify or tamper with storage unit and other components of the system. ● Risk of injury by hoisting or falling system ● Inverters and batteries are heavy and personal injury can be caused if the inverter or battery is improperly lifted or dropped during transport or improper operation when attached or removed from walls. Lifting and moved the products shall be conducted by more than one person.
	<p>Note!</p> <ul style="list-style-type: none"> ● Do not extend other brands of batteries at the battery port. ● Storage unit outputs AC power directly to the utility grid and the backup loads. Do not reverse output of these two AC terminals of the inverter.

2.2 Explanation of Symbols

This section explains all the symbols shown on the inverter and on the type label.

	<p>CE mark. The inverter complies with the requirements of the applicable CE guild lines.</p>
	<p>Dangerous electrical voltage The device is directly connected to public grid, thus all work to the battery shall only be carried out by qualified personnel.</p>
	<p>No open flames Do not place or install near flammable or explosive materials.</p>
	<p>Corrosive substance Keep the inverter away from corrosive substance.</p>
	<p>Attention Install the product out of reach of children</p>

	<p>Danger of hot surface The components inside the device will release a lot of heat during operation. Do not touch metal plate housing of the inverter during operating.</p>
	<p>Danger. Risk of electric shock!</p>
	<p>An error occurred Read the usage manual to troubleshoot problems</p>
	<p>This device SHALL NOT be disposed of in residential waste Please go to Chapter Seven “Battery maintenance” for proper treatment.</p>
	<p>Recyclable</p>

2.3 Emergency situation

Despite of its careful and professional protection design against any hazard results, damage of the battery may still occur. If a small amount of battery electrolyte is released due to a serious damage of the outer casing; or if the battery explodes due to not being treated timely after a fire breaks out nearby, and leaks out poisonous gases such as carbon monoxide, carbon dioxide etc., the following actions are recommended:

- 1) Eye contact: Rinse eyes with a large amount of running water and seek medical advice
- 2) Contact with skin: Wash the contacted area with soap thoroughly and seek medical advice
- 3) Inhalation: If you feel discomfort, dizziness or vomiting, seek medical advice immediately.
- 4) Use a FM-200 or Carbon Dioxide (CO₂) fire extinguishers to extinguish the fire if there is a fire in the area where the battery pack is installed. Wear a gas mask and avoid inhaling toxic gases and harmful substances produced by the fire.
- 5) Use an ABC fire extinguisher, if the fire is not caused by battery and not spread to it yet.

**Warning!**

- If a fire has just occurred, try to disconnect the battery circuit breaker and cut off the power supply first, but only if you can do so without endangering yourself.
- If the battery is on fire, do not attempt to extinguish the fire and evacuate the crowd immediately.

Potential danger of damaged battery:

Chemical Hazard: Despite of its careful and professional protection design against any hazard results, rupture of battery shall still occur due to mechanical damage, internal pressure etc., and may result in a leakage of battery electrolyte. The electrolyte is corrosive and flammable. When there is fire, the toxic gases produced will cause skin and eyes irritation, and discomfort after inhalation. Therefore:

- 1) Do not open damaged batteries.
- 2) Do not damage the battery again (shock, fall, trample, etc.).
- 3) Keep damaged batteries away from water (except to prevent an energy storage system from catching fire).
- 4) Do not expose the damaged battery to the sun to prevent internal heating of the battery.

Electrical hazard: The reason of fire and explosion accidents in lithium batteries is battery explosion. Here are the main factors of battery explosion:

- 1) Short circuit of battery. Short circuit will generate high heat inside battery, resulting in partial electrolyte gasification, which will stretch the battery shell. The temperature reaching ignition point of internal material will lead to explosive combustion.
- 2) Overcharge of battery. Overcharge of battery may precipitate lithium metal. If the shell is broken, it will come into direct contact with the air, resulting in combustion. The electrolyte will be ignited at the same time, resulting in strong flame, rapid expansion of gas and explosion.

3 Introduction

3.1 Scope of application

Thor Hybrid Storage Unit has two PV inputs and is used in new installation systems.

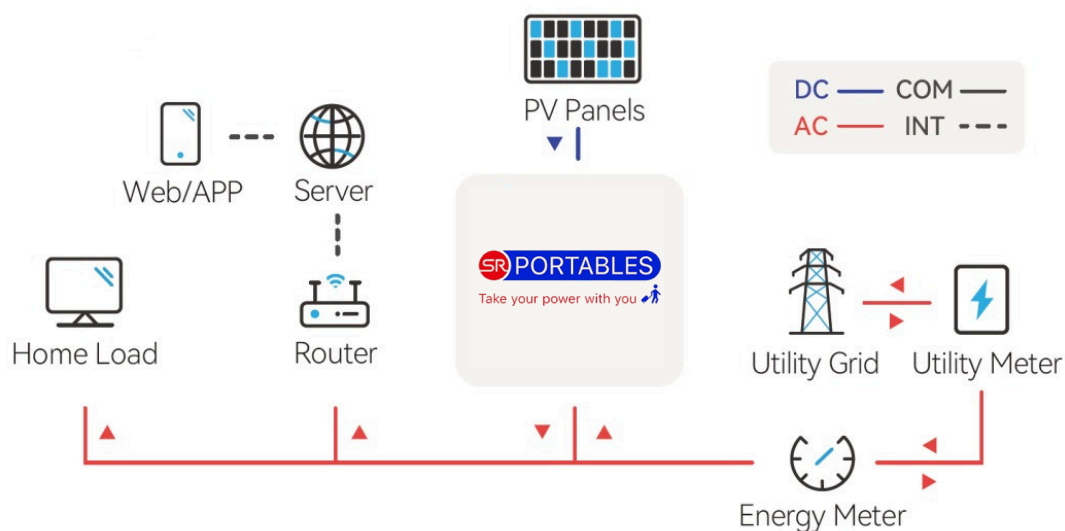

In daytime, solar power supports the loads first while the surplus power will be stored by storage unit, to improve self-consumption rate.

In peak power price hours, power from storage unit supports the loads; while in valley power price hours, storage unit is charged by the grid. Finally, a balance could be realized.

In case of grid fault, storage unit will make sure no outage in the loads, achieving UPS function.

Storage unit has two parts, inverter and battery. Storage unit can have a capacity expansion according to user demands and the modular design of the slave device makes it easy to install wiring.

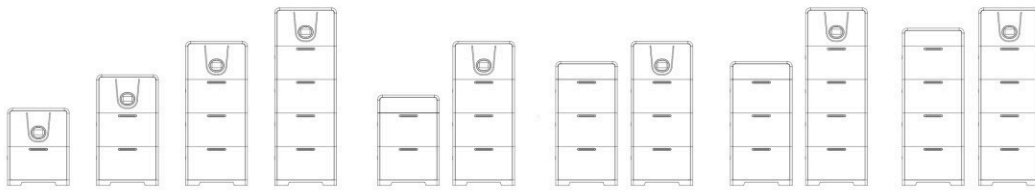

Quantity of Inverter	Quantity of Battery	System Capacity
1	1	5.12kWh
1	2	10.24kWh
1	3	15.36kWh
1	4	20.48kWh
1	5	25.6kWh
1	6	30.72kWh
1	7	35.84kWh
1	8	40.96kWh

3.2 Product Model Description

Thor - 3K0 L

① ② ③

- ① **Thor** is the name of All-In-One Storage Unit.
- ② **3K0** indicates the rated power of the hybrid inverter, such as 3.0K for 3kW.
- ③ **L** indicates that the system is a low-voltage system.

BAT1 – 5120 MT

① ② ③

- ① **Thor Bat-1** is the name of the Battery Module section in the All-In-One Storage Unit.
- ② **5120**:5.12kWh /**2560**:2.56kWh/**3580**:3.58kWh.
- ③ **MT**: Wall hanging.

3.3 Datasheet

Hybrid Inverter	Thor-3K0L	Thor-3K6L	Thor-4K0L
PV Input			
Max. PV Array Power [Wp]@STC	4500	5400	6000
Max. DC Input Voltage [V]	550		
MPPT Voltage Range [V]	80~500		
Rated DC Voltage [V]	380		
Start Voltage [V]	120		
Max. DC Input Current [A]	14/14		
Max. DC Short Circuit Current [A]	16/16		
Quantity of MPPT	2		
Battery Data			
Battery Type	LiFePO ₄		
Battery Capacity per Kit [kWh]	5.12		
Rated Voltage [V]	51.2		
Voltage range [V]	44.8-57.6		
Depth Of Discharge [DOD]	≤90%		
Max. Charging Power [W]	3000	3680	4000
Max. Charging Current [A]	60	72	80
Max. Discharging Current [A]	60	72	80
Scalability	Yes (up to 40.96kWh)		
Grid Data			
Rated Output Power [W]	3000	3680	4000
Max. Continuable Output Power [VA]	3300	3680	4400
Rated Output Current [A]	13	16	17.4
Max. Output Current [A]	14.3	16	19.1
Rated Grid Voltage/Range [V] ^[1]	220, 230, 240, L+N+PE		
Rated Grid Frequency/Range [Hz] ^[1]	50/60		
Power factor [cos φ]	0.8 leading~0.8 lagging		
THDi	< 3%		
AC Output [Back-up Mode]			
Max. Continuable Output Power [VA]	3000	3680	4000
Output Voltage [V]	220/230/240		
Max. Output Current [A]	13	16	17.4
Output Frequency [Hz]	50/60		
Max. Output Power [VA]	3300 ,60sec	4048 ,60sec	4400 ,60sec
General Data			
Communication Mode	Wi-Fi		
Operating Temperature Range	-30°C~+60°C		
Cooling Method	Natural Convection		
Altitude	4000m(>3000m power derating)		
Ambient Humidity	0-100% non-condensing		
Noise[dBA]	<25		
Ingress Protection	IP65		
Dimensions [H*W*D] [mm]	675*200*415 (Inverter) /675*200*365(Battery)		
Weight [kg]	34(Inverter)/53.6(Battery)		

[1] The AC voltage and frequency range may vary depending on specific country grid.

Hybrid Inverter	Thor -4K6L	Thor -5K0L	Thor -6K0L
PV Input			
Max. PV Array Power [Wp]@STC	6900	7500	9000
Max. DC Input Voltage [V]	550		
MPPT Voltage Range [V]	80~500		
Rated DC Voltage [V]	360		
Start Voltage [V]	120		
Max. DC Input Current [A]	14/14		
Max. DC Short Circuit Current [A]	16/16		
Quantity of MPPT	2		
Battery Data			
Battery Type	LiFePO ₄		
Battery Capacity per Kit [kWh]	5.12		
Rated Voltage [V]	51.2		
Voltage range [V]	44.8-57.6		
Depth Of Discharge [DOD]	≤90%		
Max. Charging Power [W]	4600	5000	6000 ^[2]
Max. Charging Current [A]	92	100	120 ^[2]
Max. Discharging Current [A]	92	100	120 ^[2]
Scalability	Yes (up to 40.96kWh)		
Grid Data			
Rated Output Power [W]	4600	5000	6000
Max. Continuable Output Power [VA]	4600	5000	6600
Rated Output Current [A]	20	21.7	26
Max. Output Current [A]	20	21.7	28.7
Rated Grid Voltage/Range [V] ^[1]	220, 230, 240, L+N+PE		
Rated Frequency/Range [Hz] ^[1]	50/ 60		
Power factor [cos φ]	0.8 leading~0.8 lagging		
THDi	< 3%		
AC Output [Back-up Mode]			
Max. Continuable Output Power [VA]	4600	5000	6000 ^[2]
Output Voltage [V] ^[1]	220/230/240		
Max. Output Current [A]	20	21.7	26 ^[2]
Output Frequency [Hz] ^[1]	50/60		
Max. Output Power [VA]	5060 ,60sec	5500 ,60sec	6600 ,60sec
General Data			
Communication Mode	Wi-Fi		
Operating Temperature Range	-30~+60℃		
Cooling Method	Natural Convection		
Altitude	4000m(>3000m power derating)		
Ambient Humidity	0-100% non-condensing		
Noise[dBA]	<25		
Ingress Protection	IP65		
Dimensions [H*W*D] [mm]	675*200*415 (Inverter) /675*200*365(Battery)		
Weight [kg]	34(Inverter)/53.6(Battery)		

[1] The AC voltage and frequency range may vary depending on specific country grid.

[2] Storage unit needs at least two batteries to reach >6000W output.

Hybrid Inverter		Thor -8K0L
PV Input		
Max. PV Array Power [Wp]@STC		12000
Max. DC Input Voltage [V]		550
MPPT Voltage Range [V]		80~500
Rated DC Voltage [V]		360
Start Voltage [V]		120
Max. DC Input Current [A]		14/28
Max. DC Short Circuit Current [A]		16/32
Quantity of MPPT		2
Battery Data		
Battery Type		LiFePO4
Battery Capacity per Kit [kWh]		5.12
Rated Voltage [V]		51.2
Voltage range [V]		44.8-57.6
Depth Of Discharge [DOD]		≤90%
Max. Charging Power [W]		8000 ^[2]
Max. Charging Current [A]		160 ^[2]
Max. Discharging Current [A]		160 ^[2]
Scalability		Yes (up to 40.96kWh)
Grid Data		
Rated Output Power [W]		8000
Max. Continuable Output Power [VA]		8800
Rated Output Current [A]		35
Max. Output Current [A]		38.3
Rated Grid Voltage/Range [V] ^[1]		220, 230, 240, L+N+PE
Rated Grid Frequency/Range [Hz] ^[1]		50/60
Power factor [cos φ]		0.8 leading~0.8 lagging
THDi		< 3%
AC Output [Back-up Mode]		
Max. Continuable Output Power [VA]		8000 ^[2]
Output Voltage [V] ^[1]		220/230/240
Max. Output Current [A]		35 ^[2]
Output Frequency [Hz] ^[1]		50/60
Max. Output Power [VA]		9600 ,60sec
General Data		
Communication Mode		Wi-Fi
Operating Temperature Range		-30~+60℃
Cooling Method		Natural Convection
Altitude		4000m(>3000m power derating)
Ambient Humidity		0-100% non-condensing
Noise[dBA]		<25
Ingress Protection		IP65
Dimensions [H*W*D][mm]		675*200*415 (Inverter) /675*200*365(Battery)
Weight [kg]		34(Inverter)/53.6(Battery)

[1] The AC voltage and frequency range may vary depending on specific country grid.

[2] Storage unit needs at least two batteries to reach >6000W output.

Battery Module	THOR BAT-1
Electrical Parameter	
Battery Type	LiFePO ₄
Battery Capacity per Kit [Wh]	5120
Usable Energy [Wh]	4600
Rated Voltage [V]	51.2
Voltage range [V]	44.8-57.6
Max. Charging and Discharging Rate	1C
Depth Of Discharge [DOD]	≤90%
Cycle Life(25°C,0.5C)	≥6000 times,80% Capacity retention
General Data	
Communication Mode	RS485/CAN2.0
Operating Temperature Range	0~50°C (Charge)/-10~50°C(Discharge)
Storage Temperature Range	-15°C~60°C
Cooling Method	Natural Convection
Altitude	<2000m
Ambient Humidity	0-100% non-condensing
Noise[dBA]	<25
Ingress Protection	IP65
Dimensions [H*W*D][mm]	675*200*365
Weight [kg]	53.6

4 Installation Instructions

4.1 Safety Tips

Danger!



- Potential fires and electric shocks that are life threatening.
- Do not place any flammable or explosive materials beside storage unit.
- Equipment connected to high-voltage power generation equipment must be performed by qualified personnel in compliance with national and local standards and regulations.



Note !







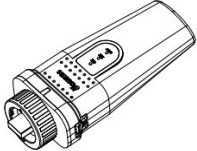
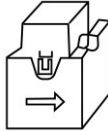

- The pollution level applicable to storage unit is Class II.
- Inappropriate or inconsistent installation environment can shorten the life of storage unit.
- Do not install storage unit directly by exposing it under strong sunlight.
- Please do not install in damp places.
- The installation location must be well ventilated.
- Storage unit (hereinafter also referred to as the master device) can be used with one battery. If the battery capacity needs to be expanded, please use Thor Bat-1 (slave device), and maximum 4 batteries are supported for the whole system.

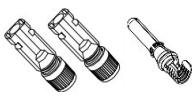
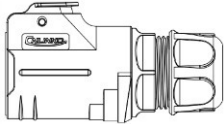
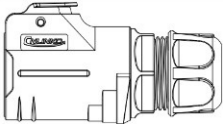
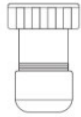
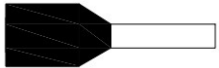
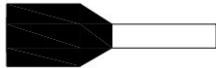
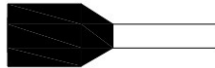
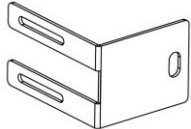

4.2 Packing List







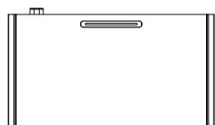
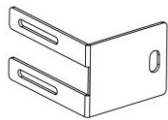

Hybrid Inverter

			
1* Hybrid Inverter	1* User Manual	1* Monitor Module	1* CT

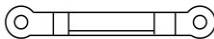

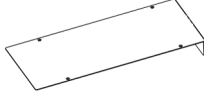
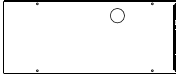

			
2* PV+ Input Terminal; 2* Secured Metal Terminals to PV+ Input Power Cables (8K Model Equipped With 3 Pcs)	2* PV- Input Terminal; 2* Secured Metal Terminals to PV- Input Power Cables (8K Model Equipped With 3 Pcs)	1* Waterproof Aviation Male Pin Plug	1* Waterproof Aviation Female Pin Plug
			
1* Waterproof Terminal	2* Tube Terminal (Red)	2* Tube Terminal (Black)	2* Tube Terminal (Yellow)
			
2* Fixed Support Rack	4* Round Head Screws M3*5	4* SEM Screw M4*10	2* Expansion Screw M6
			
1* Allen Wrench D-3mm L Type	1* Qualified Certificate	1* Packing List	

Storage Battery

			
1* Battery	2* Fixed Support Rack	2* Expansion Screw M6	4* Round Head Screws M3*5

			
4* SEM Screw M4*10	4* Guide Pin	1* Grounding Cable	1* Qualified Certificate
			
1* Right Side Cover	1* Left Side Cover	1* Cable Grommet	8* Countersunk Screw
			
1* Packing List			

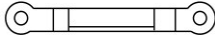
Base

		
1* Base	4* Guide Pin	1* Grounding Cable
		
1* Qualified Certificate	1* Packing List	

4.3 Determine the installation method and location

Inverter dimension (mm) :

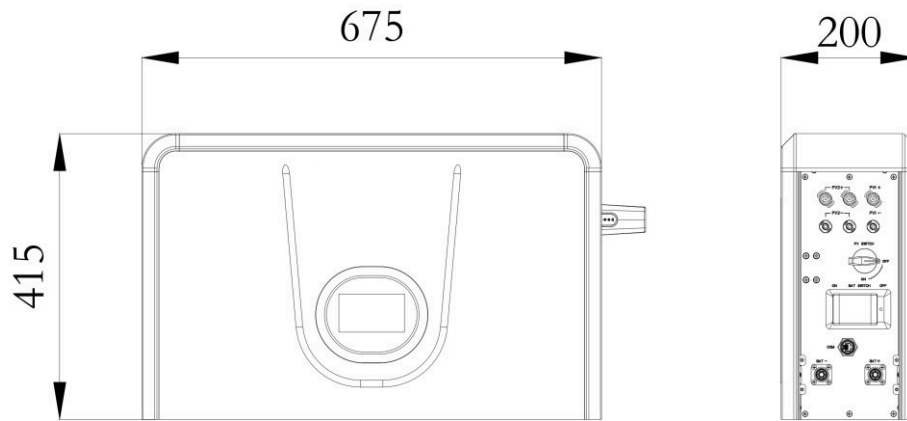

Battery dimension (mm) :

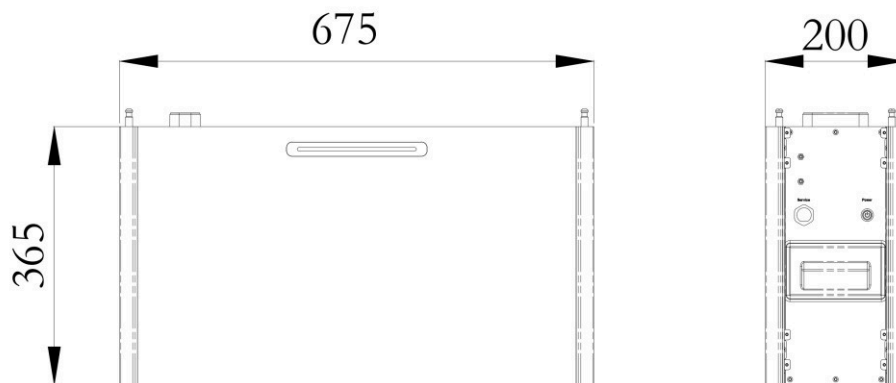

Base dimension (mm) :

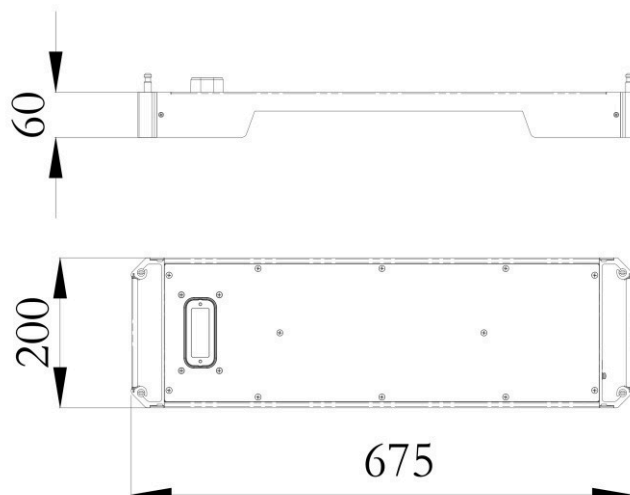

Storage unit is cooled by natural wind convection. It is recommended to install in indoors or sheltered areas to avoid direct sunlight, rain and snow.

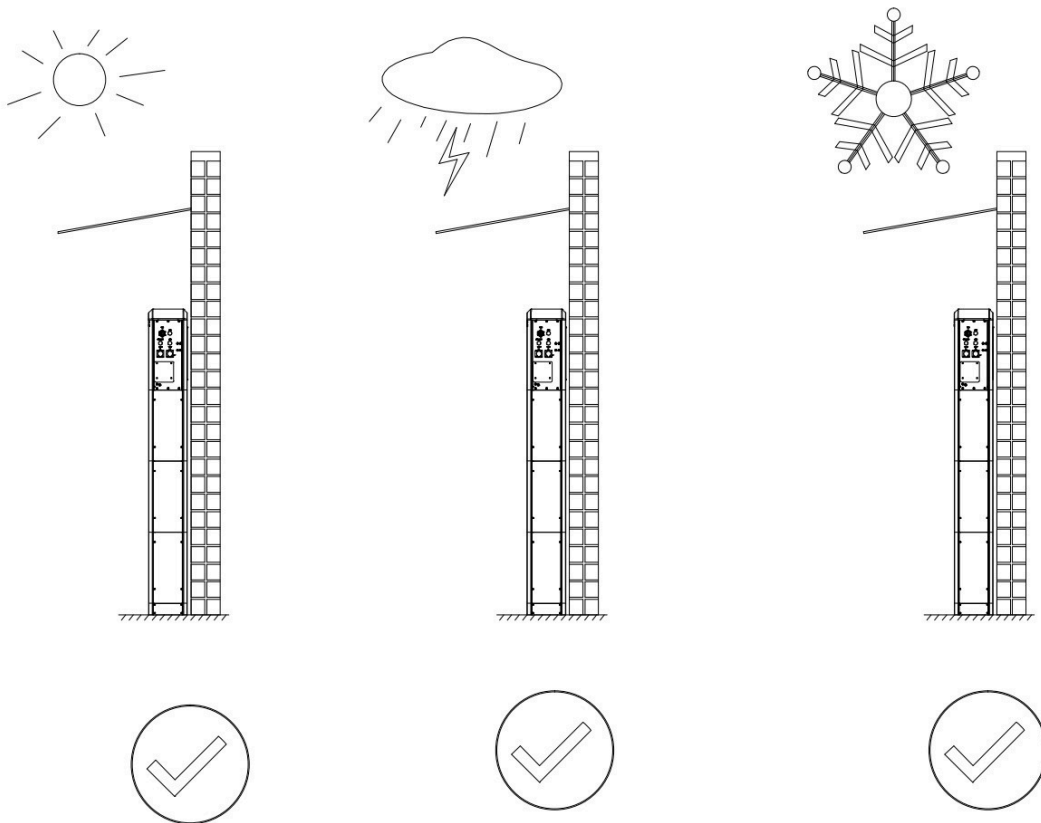
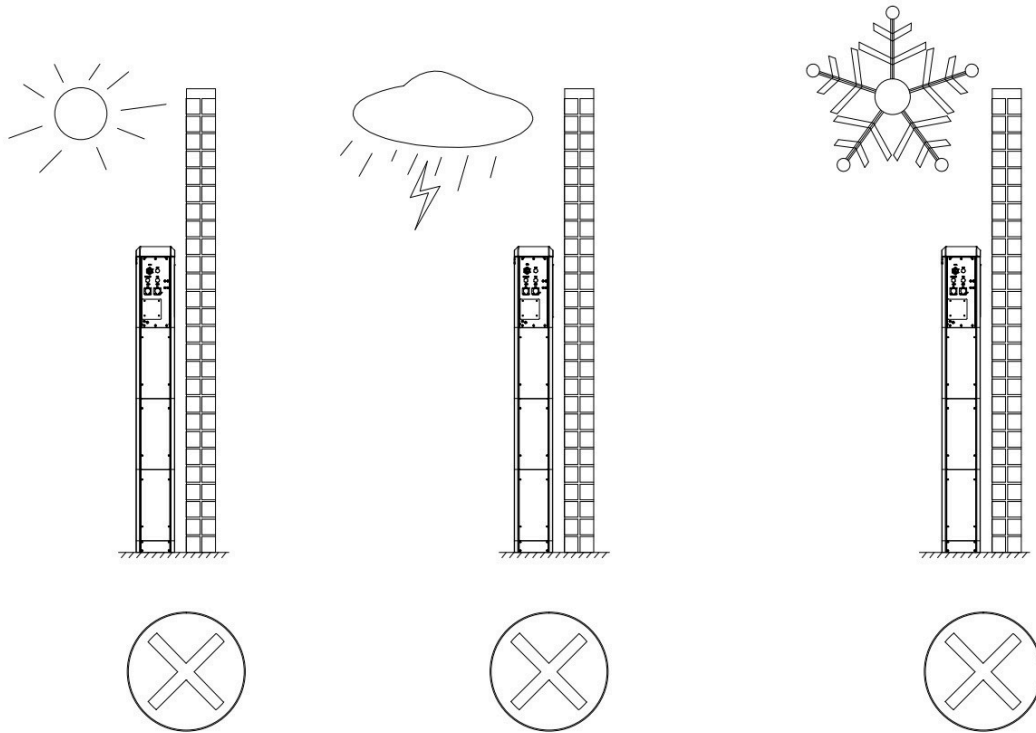

Please ensure that the air at the installation point is circulated. Bad air ventilation will affect the working performance of internal electronic components and shorten the service life of storage unit.

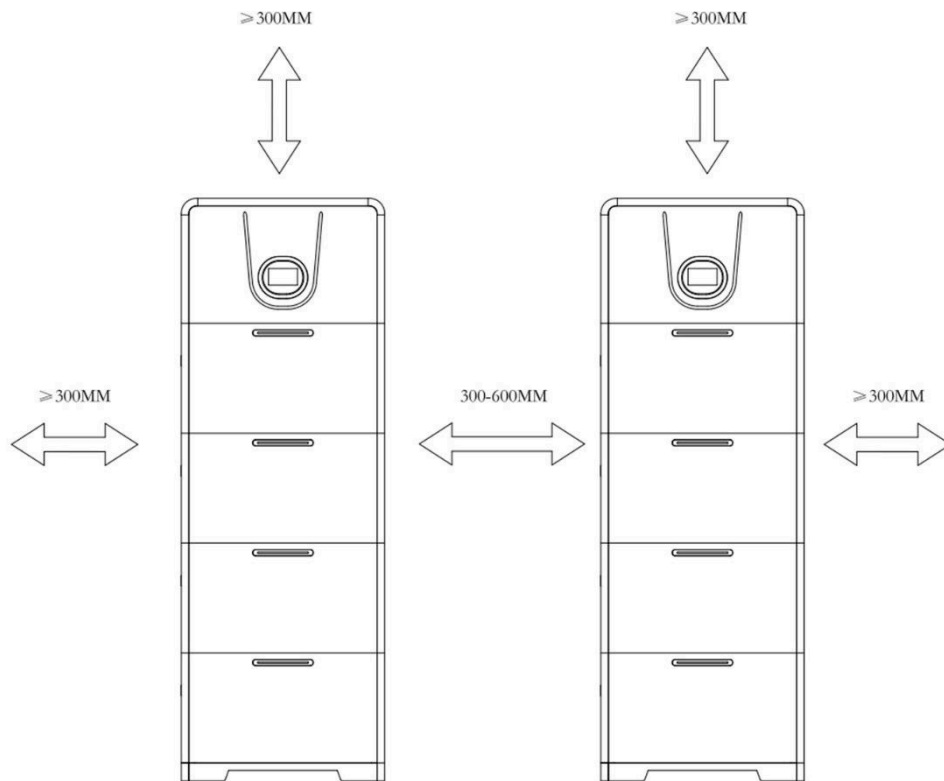

The following sites are not allowed for installation:

- within 600mm of any exit.
- within 600mm of any vertical side of a window or building ventilation that ventilates a habitable room.
- in ceiling spaces.
- in wall cavities or under stairways.
- on roofs, except for were specially deemed suitable.
- under access walkways.
- sites where the freezing point is reached, like garages, carports or other places.
- places with plenty of salt.
- flooded areas.
- within 600mm of any hot water unit, air conditioning unit or any other appliance associated with the pre-assembled integrated battery energy storage system.

4.4 Preparations before installation

Step 1: Take out the inverter, battery and base from the packing box.

Step 2: Preparation before base installation:

- ① Use screwdriver to loosen the 4 screws on the side of the terminal and remove the cover.
- ② Install the 4 positioning pins in the holes at the four corners of the base, and tighten them with a flathead screwdriver.

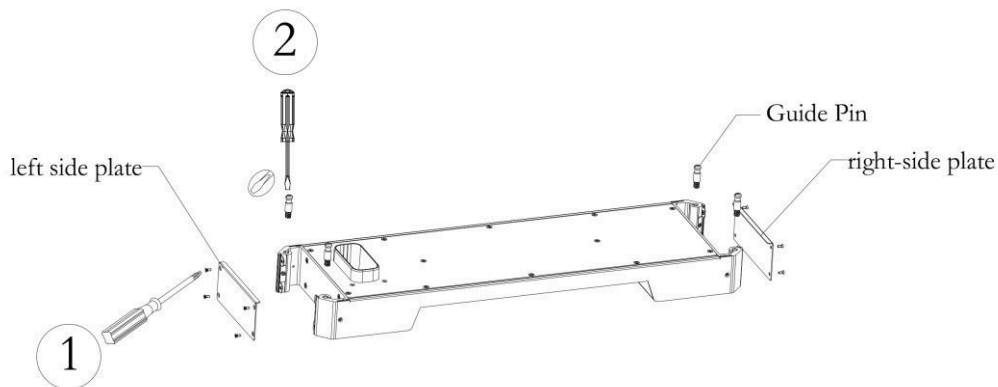

Step 3: Preparations before battery installation:

- ① Use screwdriver to loosen the cover screws on both sides.
- ② Pass the upside-down hanging ear through the mounting hole of the chassis, and fix it with screws. It needs to be adjusted later, so it does not need to be tightened.
- ③ Install the 4 positioning pins in the holes at the four corners of the battery case, and tighten them with a flathead screwdriver.

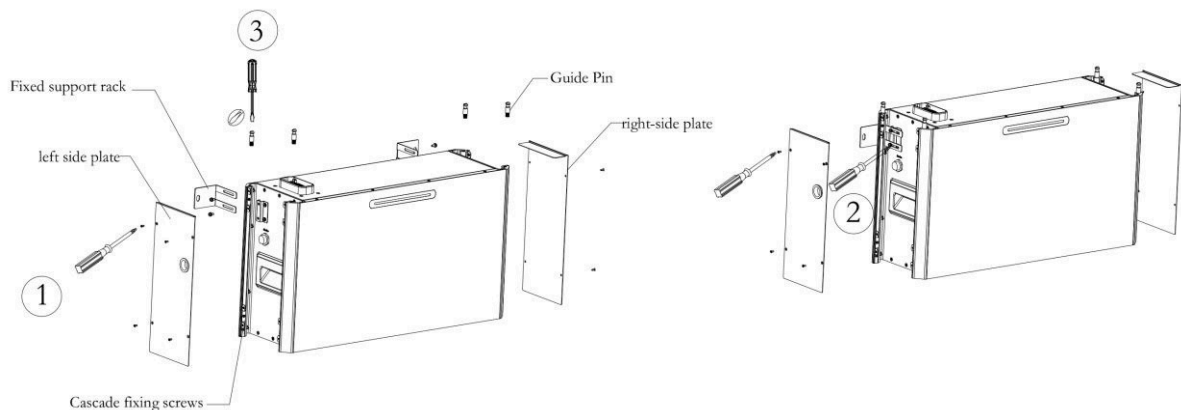

Step 4: Preparations before inverter installation:

- ① Use screwdriver to loosen the 4 fixing screws on the side cover and remove the left cover.
- ② Pass the upside-down hanging ear through the mounting hole of the chassis, and fix it with screws. It needs to be adjusted later, so it does not need to be tightened.

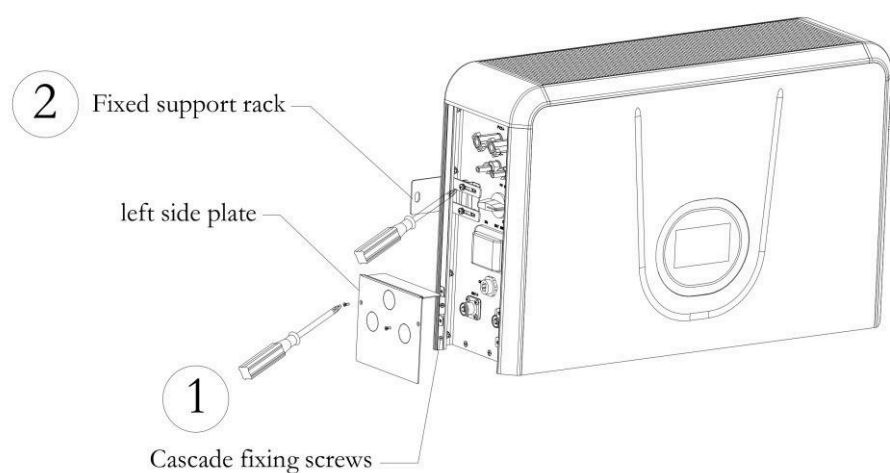

4.5 Installation steps for storage unit

Note!



- strength to fix the screws and bear the weight of inverter and battery.

Step 1: Choose the installation location, place the base, adjust it to horizontal, and the base is 10~20mm away from the wall.

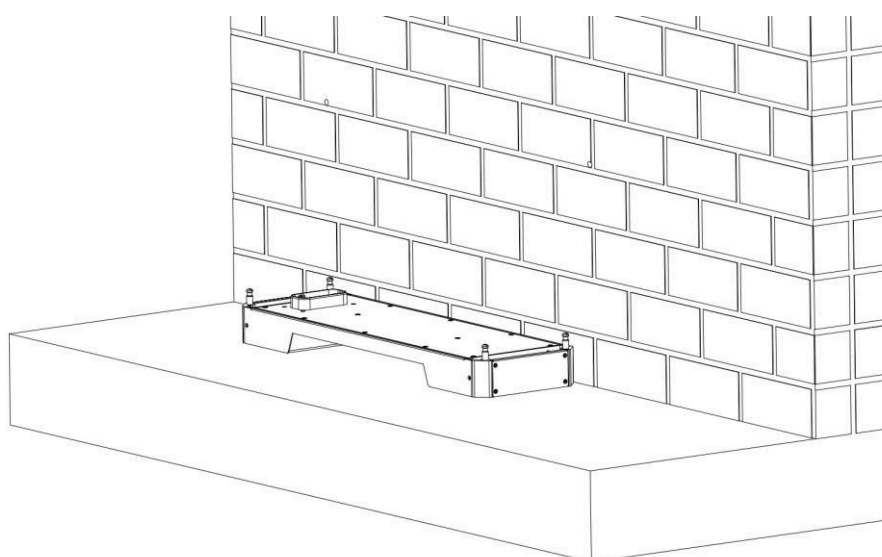

Step 2: Stack the battery module-inverter in sequence.

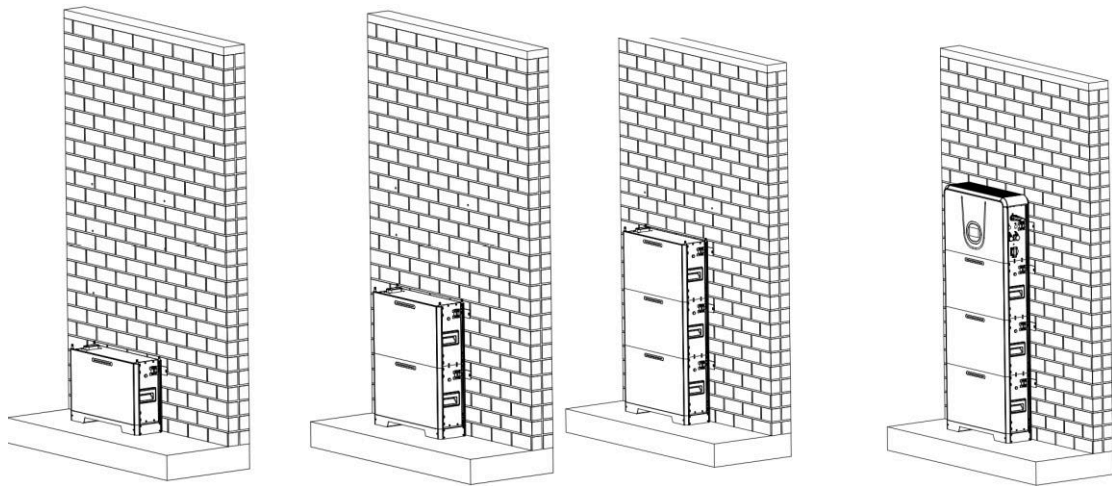

Step 3: Use a marker pen to draw a line in the hole of the wall fixture to determine the position of the screw hole.

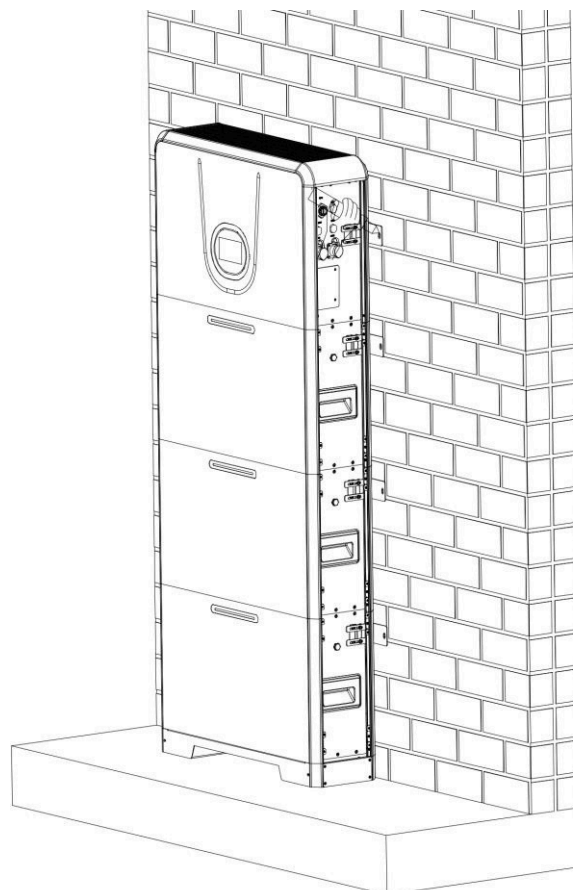

Step 4: Take down the inverter-battery box in sequence.

Step 5: Use a percussion drill to drill holes marked in Step 3 and drive in expansion screws.

Step 6: Stack the battery module-inverter in sequence, tighten the cascading fixing screws, fix the screws and wall fixing parts on the wall with a wrench, adjust the fixing bracket screws of the chassis, and adjust the distance between the chassis and the wall to an appropriate distance (10~20mm) rear locking screw.

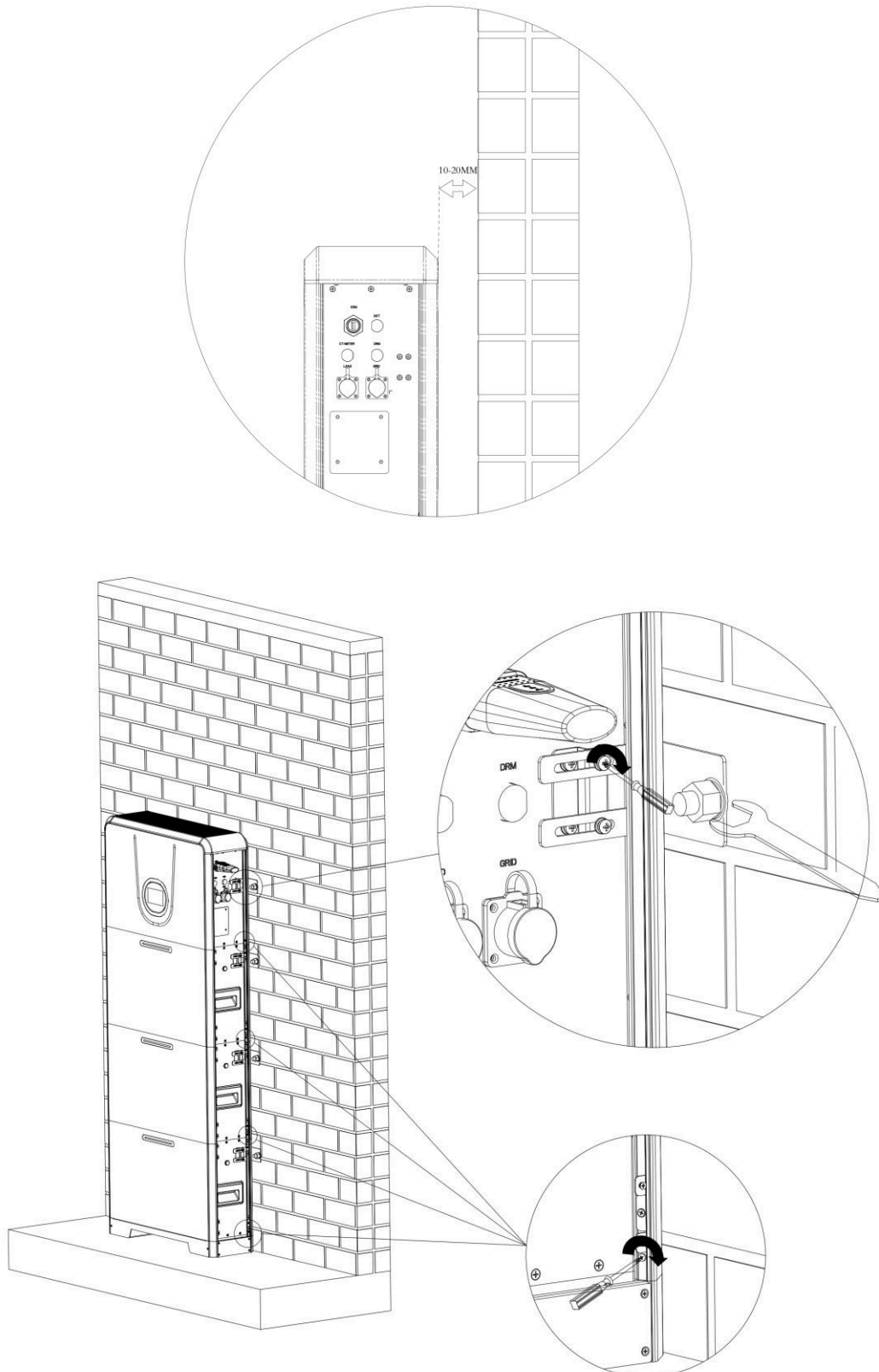

5 Electrical Connections

5.1 Electrical Interface Description

5.1.1 Inverter interface description

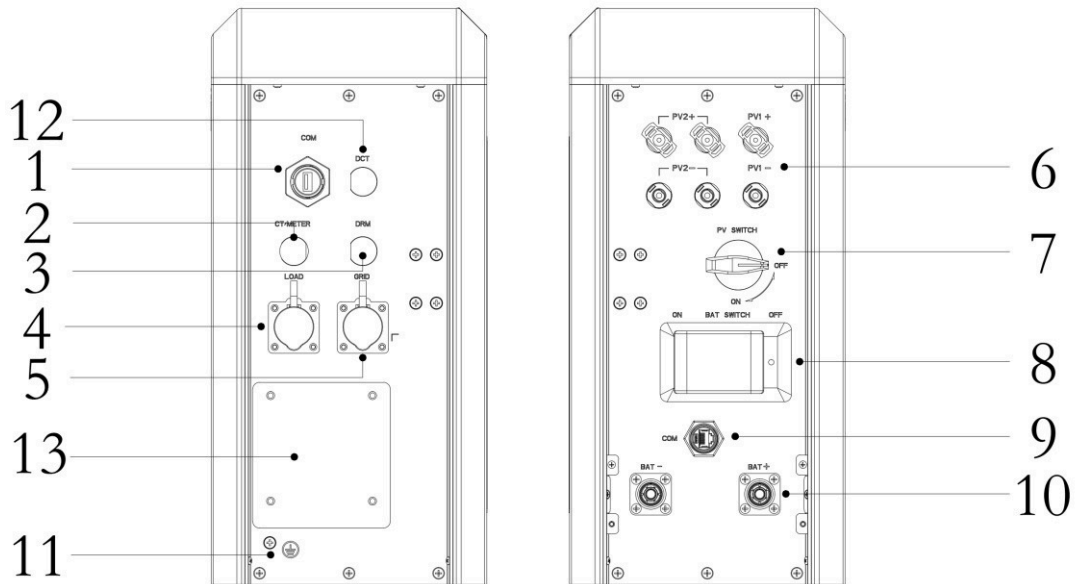

Object	Description	Object	Description
1	WiFi Port	8	Battery Switch
2	CT/Meter	9	Battery signal port
3	DRM Port	10	Battery Connection
4	Load Connection	11	Grounding screw
5	Grid Connection	12	DCT Port
6	PV INPUT port	13	Cover Plate
7	PV Switch	14	/

5.1.2 Battery interface description

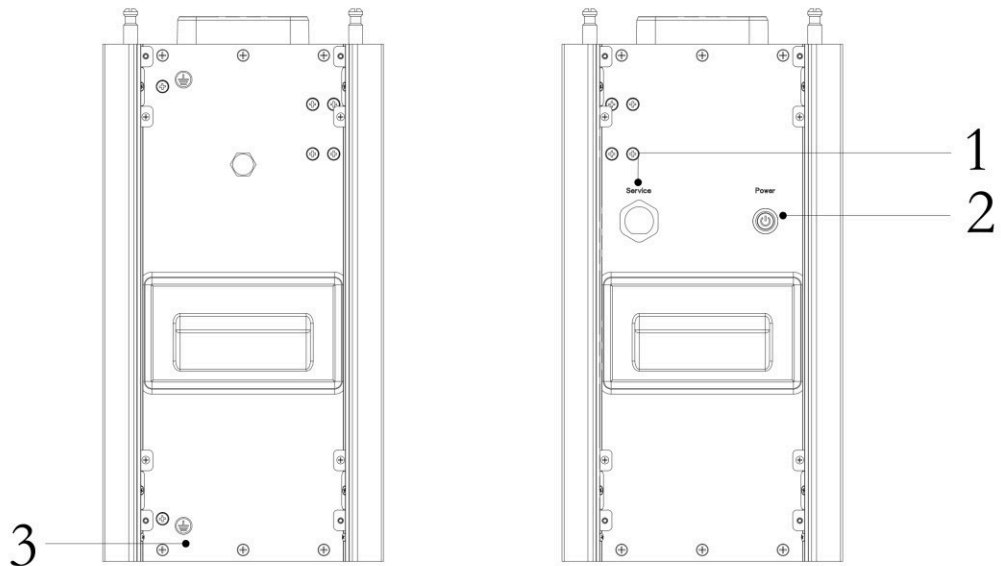

Object	Description	Object	Description
1	Service port	3	Grounding screw
2	Power button	4	/

5.1.3 Base interface description

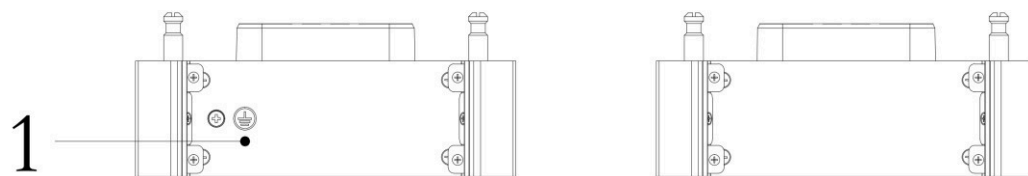

Object	Description	Object	Description
1	Grounding	2	/

5.2 System Wiring Schematic

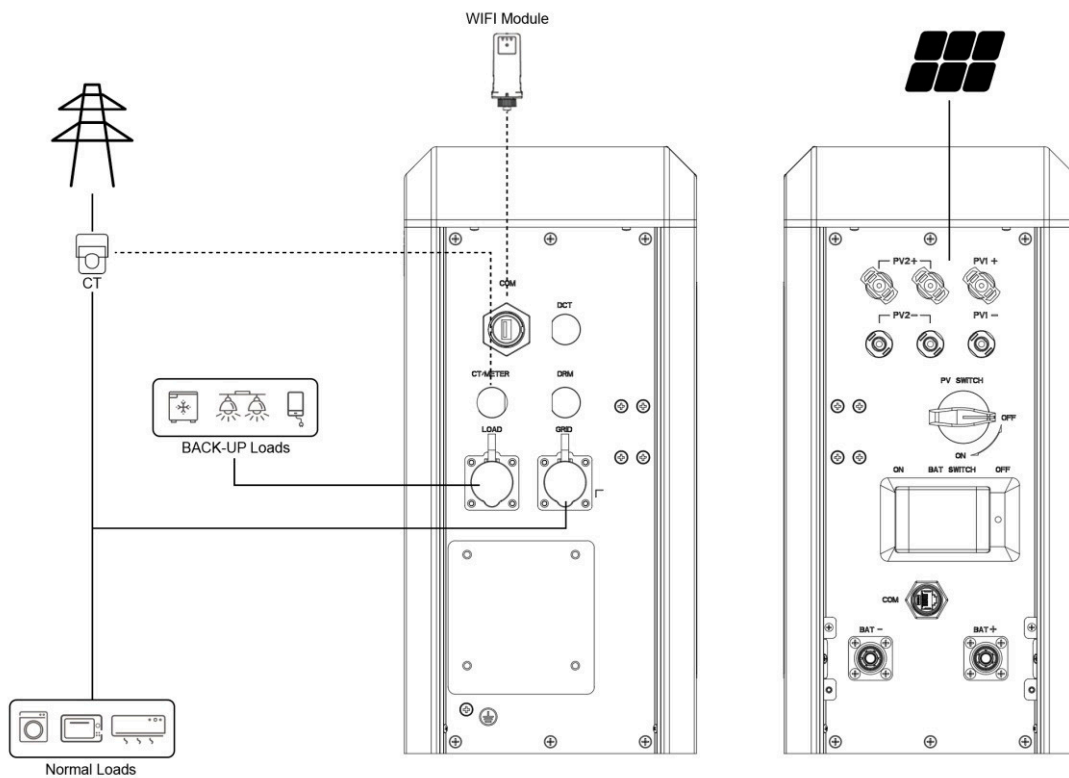

5.3 Battery Wiring



Warning!

- The Batteries are paralleled to the inverter.
- Ensure Battery switch is off during installation to avoid the risk of short circuit caused by wrong operation during battery wiring.
- Do not connect one Expansion Battery to two different inverter devices at the same time

5.3.1 Battery wiring (Battery does not expand)

If there is no dip switch, the battery with automatic recognition function, no need to operate the setup

Set the DIP switch of each battery.

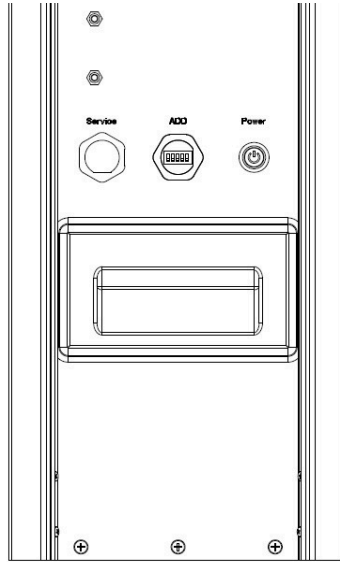

DIP switch configuration can be found below:

Configura tion	Battery (No.1)	Battery (No.2)	Battery (No.3)	Battery (No.4)	Battery (No.5)	Battery (No.6)	Battery (No.7)	Battery (No.8)
1*Inverter 1* Battery		/	//		/	/	/	/
1*Inverter 2* Battery			/	/	/	/	/	/
1*Inverter 3* Battery				/	/	/	/	/
1*Inverter 4* Battery					/	/	/	/
1*Inverter 5* Battery						/	/	/
1*Inverter 6* Battery							/	/
1*Inverter 7* Battery								/
1*Inverter 8* Battery								

5.3.2 Grounding wire connection

Take out the grounding wire and screw (M4-10), and install it to the corresponding position with a screwdriver.

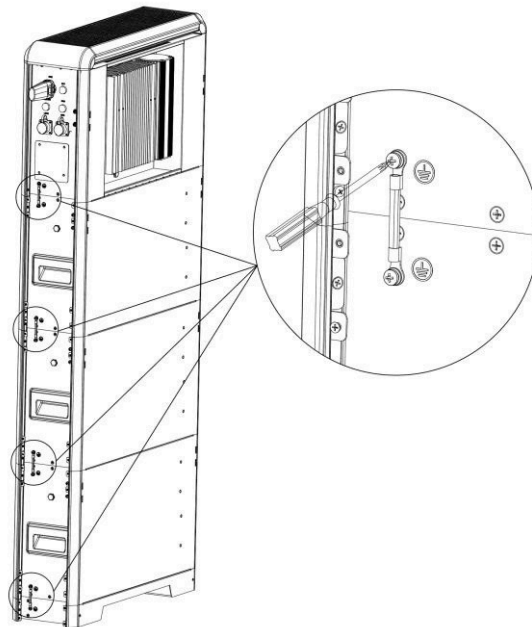

5.3.3 Side protection cover installation

After connecting the wires, find the corresponding side cover, place it in a suitable position, and screw on the fixing screws with a screwdriver.

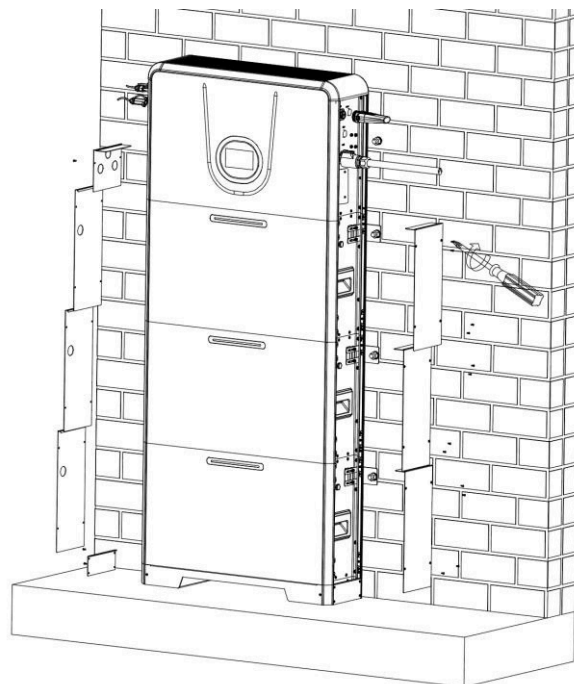

5.4 PV Input Wiring

 **Note !**

- Use 4 mm² DC cable for the DC input cable.

Step 1: Prepare PV positive and negative power cables.

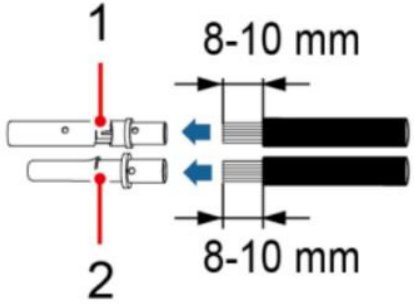
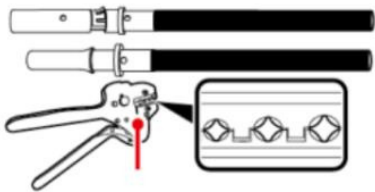
	 <p>crimping tool</p>
1. Positive connector	2. Negative connector

Step 2: Insert the crimped photovoltaic positive and negative power cable into the corresponding photovoltaic connector.

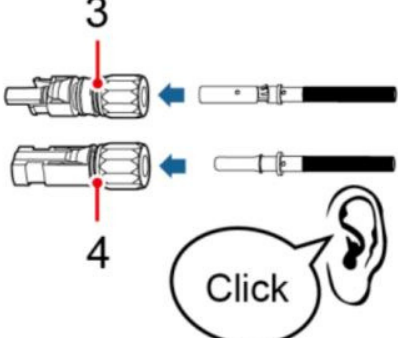
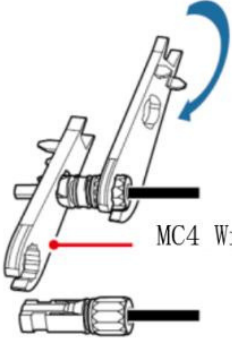
	 <p>MC4 Wrench</p>
3. Positive connector	4. Negative connector

Step 3: Insert the positive and negative connectors into the corresponding PV region of the HSU unit until a click is heard.

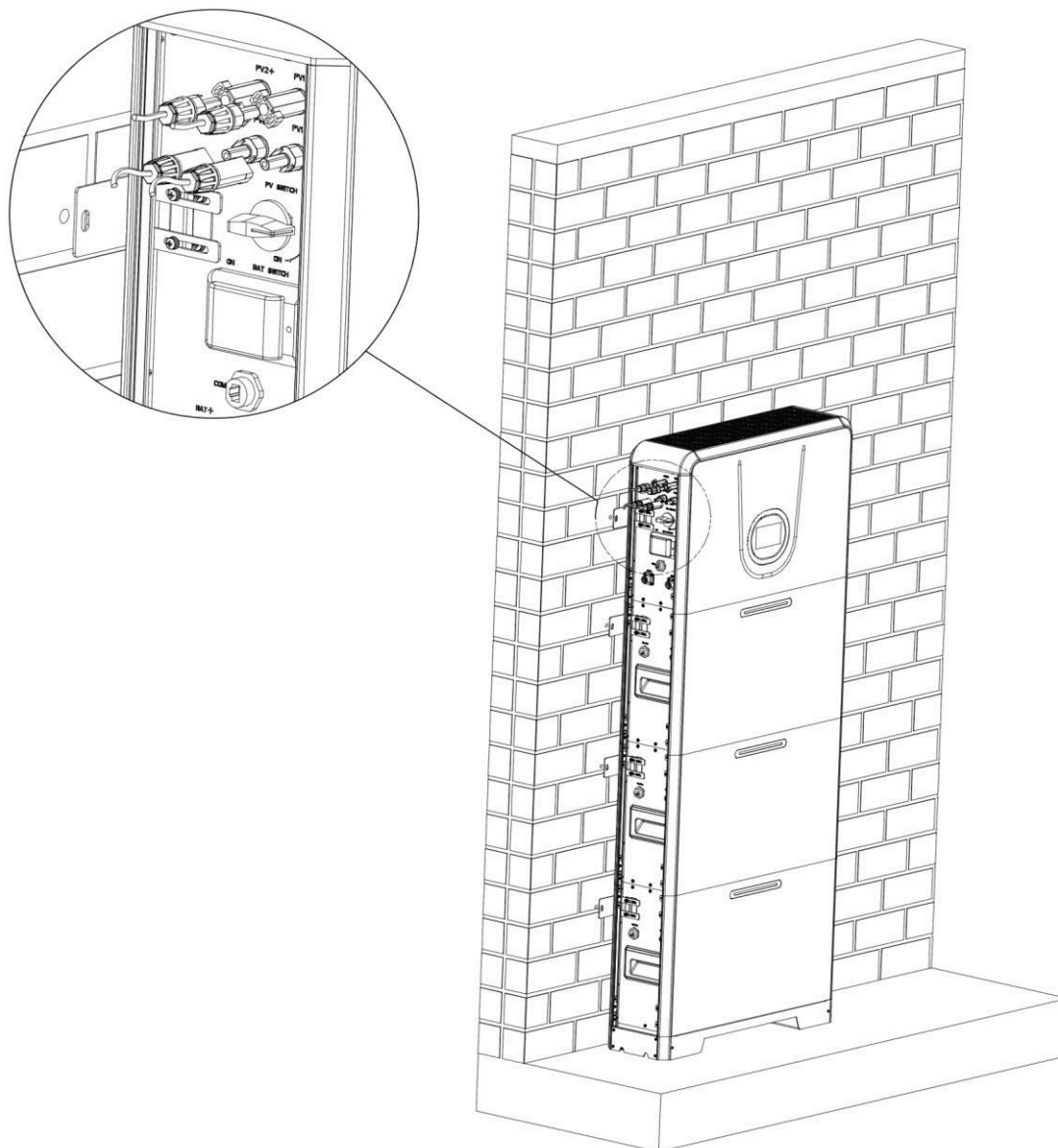

Warning!

- Make sure that the DC voltage of each PV string is less than 550V and the polarity of PV cables are correct.
- Make sure that the DC switch should be turned off.

5.5 Grid/Load Wiring



Warning!

- Turn off the Battery Switch and external AC breaker after unpacking in any cases before and during wiring in case of electric shock.
- Please be cautious when unplug battery switch cable during dismantling.

Step 1:

- ① Choose the right cable.

Cable type	Conductor cross-sectional area (mm ²)	
	Outside diameter (mm ²)	Conductor core section (mm ²)
10 AWG	5.5-8.0	4.0-6.0

- ② Peel off the cable insulation sleeve for 16 mm, as shown in Figure:



Step 2: Take out the plug accessories and disassemble the plug according to the picture.

Unscrew the 3 clamp sleeve, press the "PUSH" button on the 2 shell, and pop out the 1 terminal block.

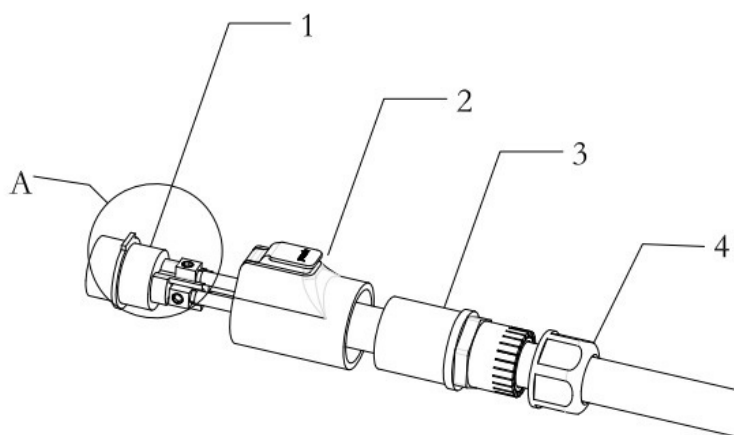

Step 3: Pass the cable through the plug part in the order of 4-3-2-1, loosen the terminal screw, insert the cable into the corresponding terminal block and lock the screw.

Cable	Number
L	1
N	2
PE	3

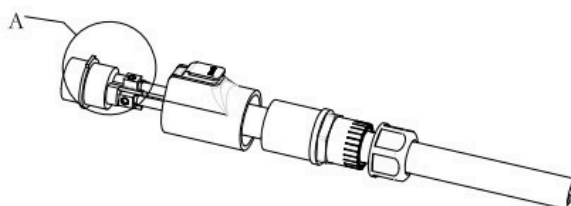
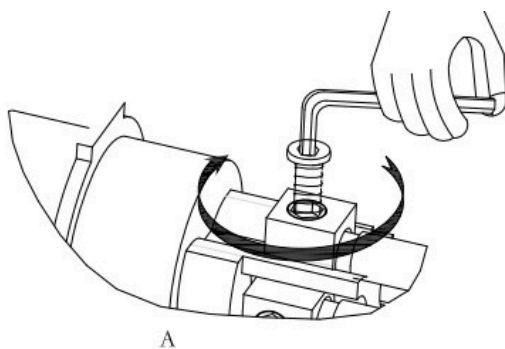
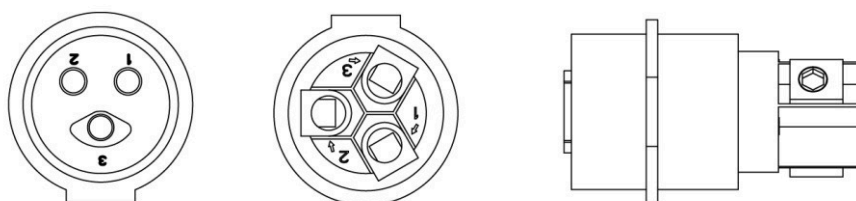

Step 4: Assemble the plug according to the picture;

- ① Press and hold the "PUSH" button on the shell, push the connected cable seat into the shell, and when you hear a "click", the installation is complete.

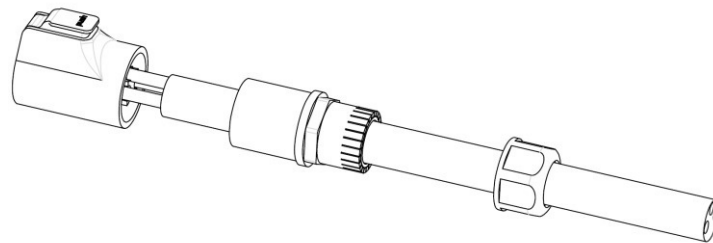
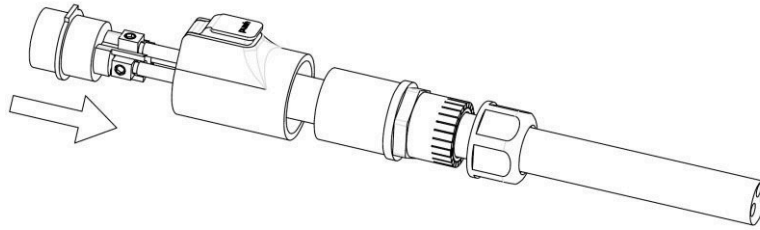

- ② Lock the clamping sleeve into the housing, lock it.

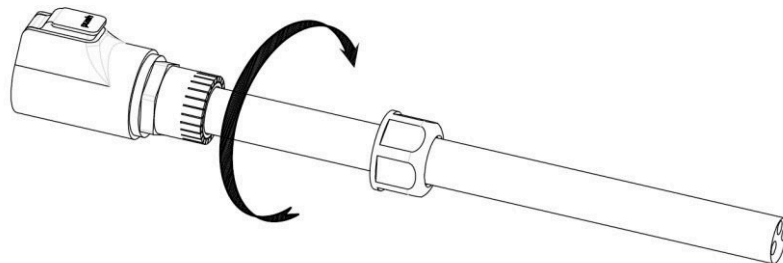

- ③ Lock the waterproof nut on the clamp sleeve.

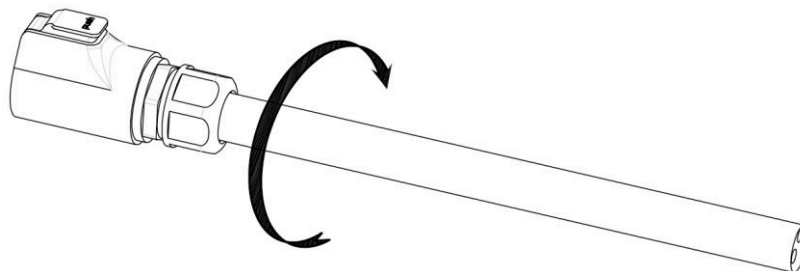

Step 5: Insert the plug into the corresponding socket, when you hear a "click", the installation is complete.

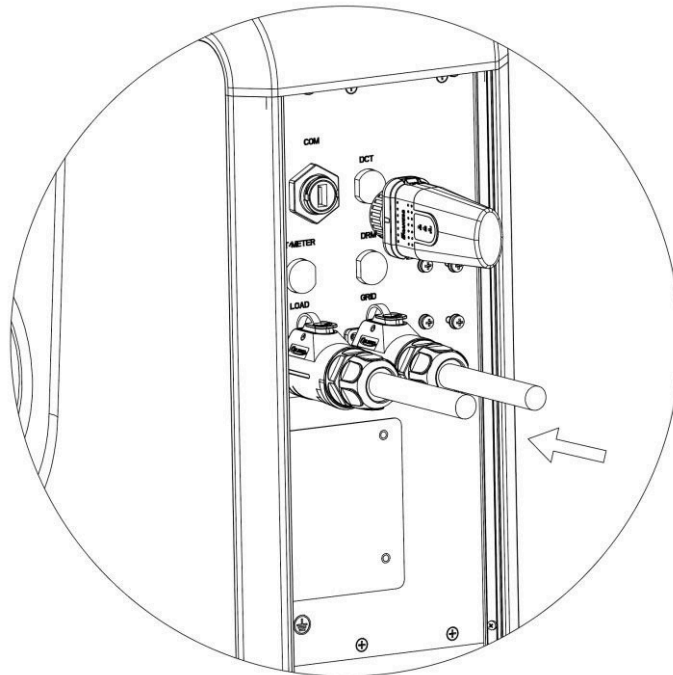

5.6 EV Charging wiring

The Thor system reserves an EV interface, which can be used with a portable AC charging cable to charge the electric car to form a home electric car charging system. The maximum EV power is $\leq 3.5\text{KW}$, and the total power of EV+AC load cannot exceed the load output power of the inverter.

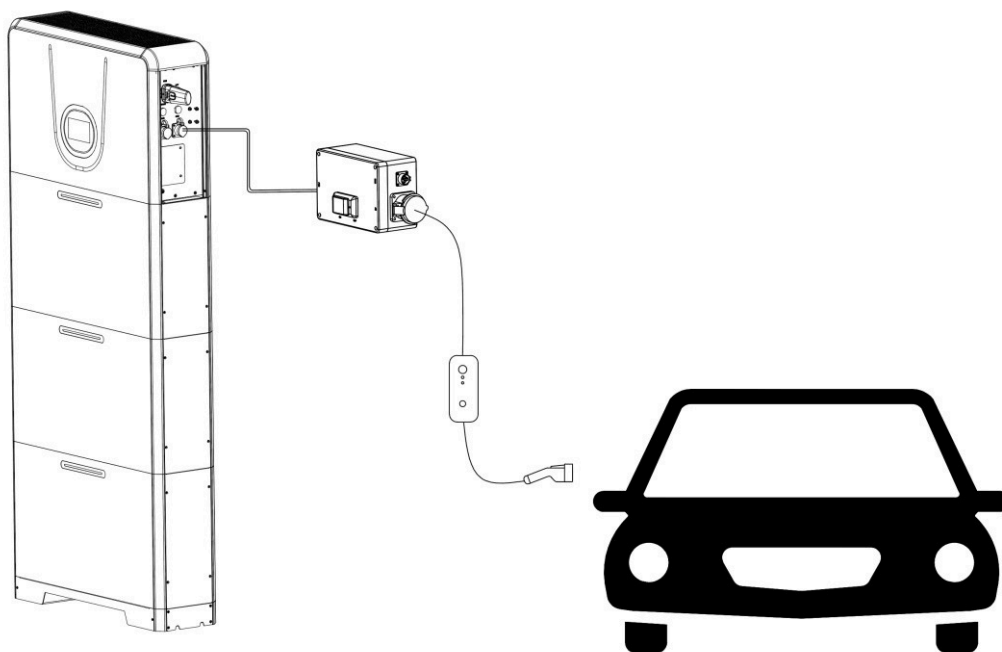

5.7 Title corresponds to the left side silk screen printing (DCT dry contact function)

The Thor machine has two sets of internal input dry contacts and one set of external output dry contacts. To use the dry contact function, a WiFi program needs to be set up. Contact the manufacturer to set the functional requirements

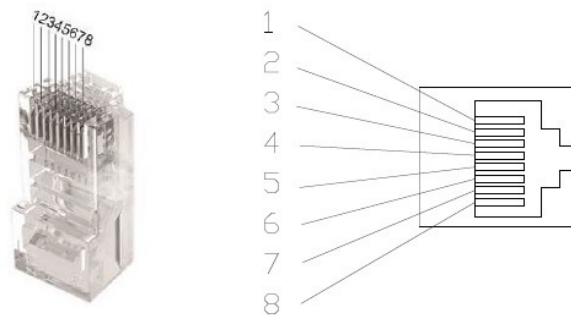

Object	Corresponding Pins	Requirement
Group A input dry contact point	1/3	NC normally closed dry contact
Group A input dry contact point	1/2	N0 normally open dry contact
B group output dry contact 4/5	4/5	External short-circuit signal
Group C input dry contact point	6/8	NC normally closed dry contact
Group C input dry contact point	6/7	N0 normally open dry contact

5.8 External current detection

CT solution is offered for sampling data of grid side as standard solution.

Please install CT with instructions as below:

- 1) Lead the Live line through the CT.
- 2) Tighten up the CT buckles.
- 3) Remove the cover of CT port on the right side of inverter.
- 4) Connect RJ45 plug of the CT to the CT port

	<p>Note !</p> <ul style="list-style-type: none"> ● CT direction shall point to the grid side. ● Please notice the CT direction. The CT should be installed near the grid.
---	--

Write CT/Meter connection method

When performing load matching function, the output power of the inverter is the sum of the total power paper, CT and single-phase meters are at this power, and three-phase meters are at P total power.

CT

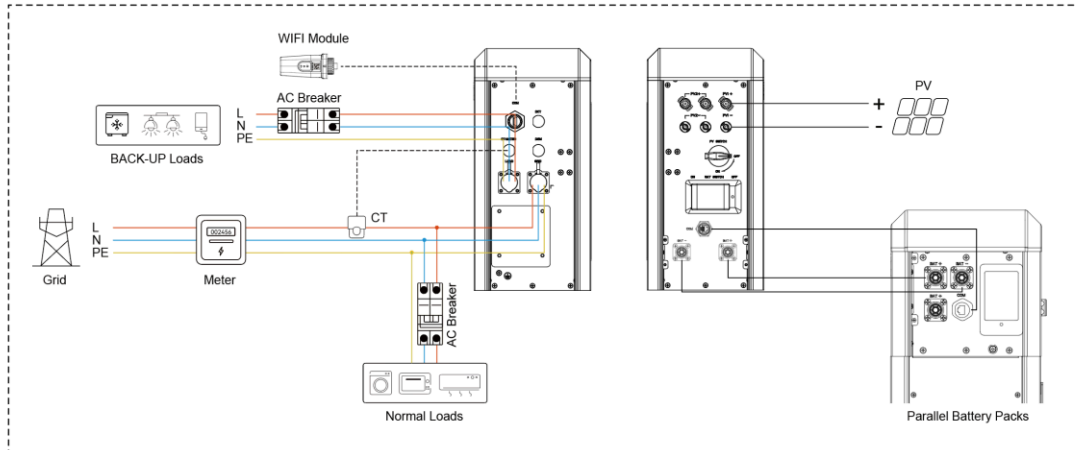

Single-Phase Meter

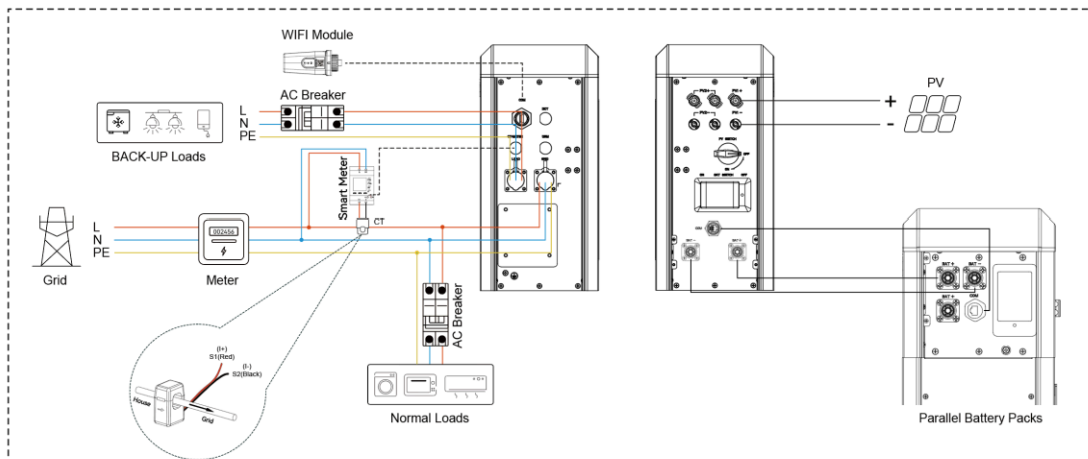

Three-Phase Meter

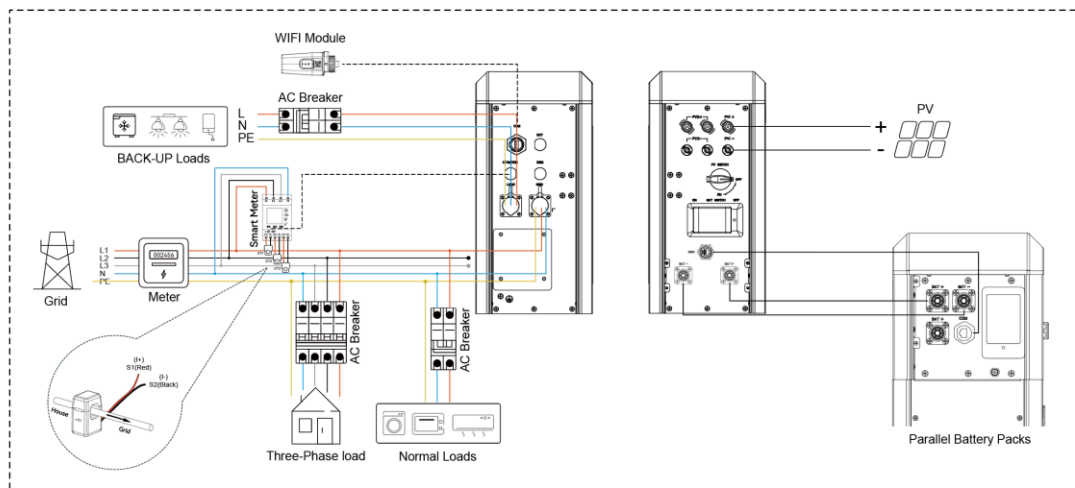

If an external electric meter is selected, the CT port 1 line position 485-A and the CT port 2 line position 485-B need to be operated on the display screen interface to determine whether the corresponding electric meter model is single-phase or three-phase (default is CT)

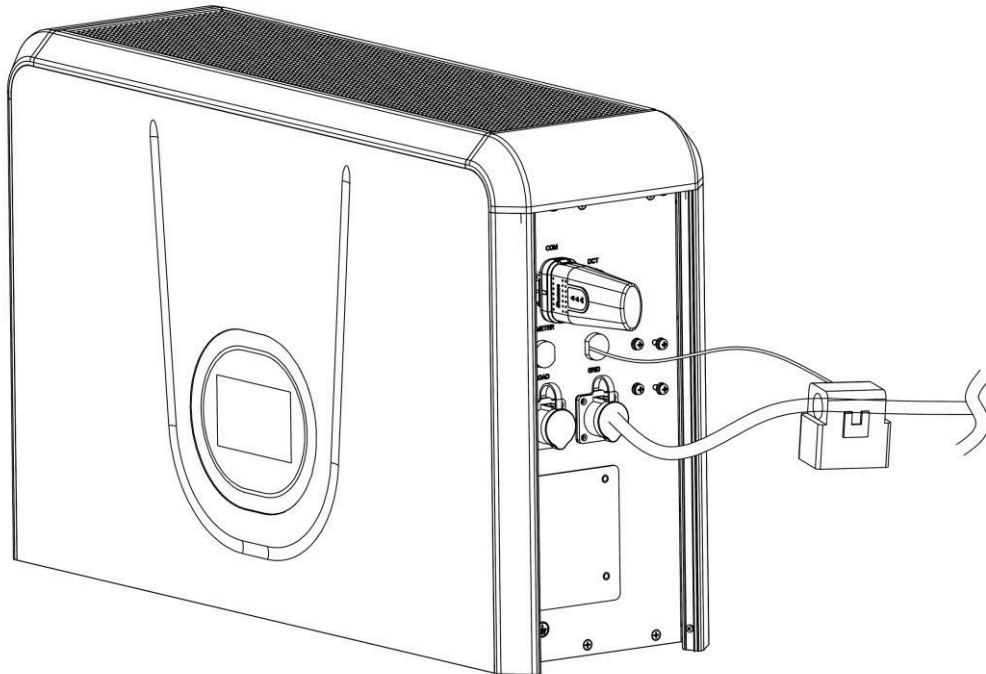

5.9 External AC Circuit Breaker and Residual Current Device

Please install a circuit breaker to ensure the inverter is able to disconnect from grid safely. The inverter is integrated with a RCMU; however, an external RCD is needed to protect the system from tripping, either type A or type B RCD are compatible with the inverter.

The integrated leakage current detector of inverter is able to detect the real time external current leakage. When a leakage current detected exceeds the limitation, the inverter will be disconnected from grid quickly, if an external residual current device is connected, the action current should be 30mA or higher.

5.10 Battery expansion

Refer to 5.3.1 to connect the Thor system and another set of expansion batteries.

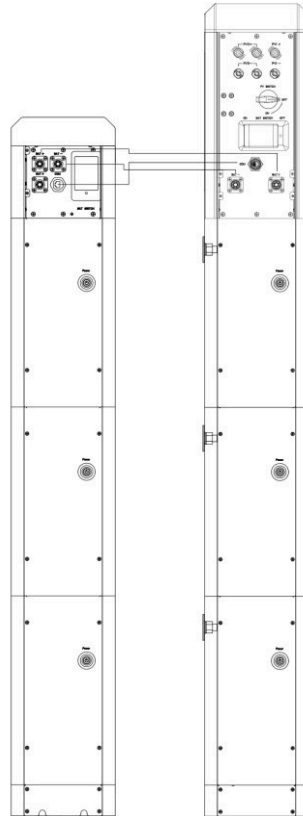

Use the accessory harness to connect two sets of batteries, the battery packs are connected in parallel, BAT + connects to BAT +, BAT – connects to BAT –, COM connects to COM.

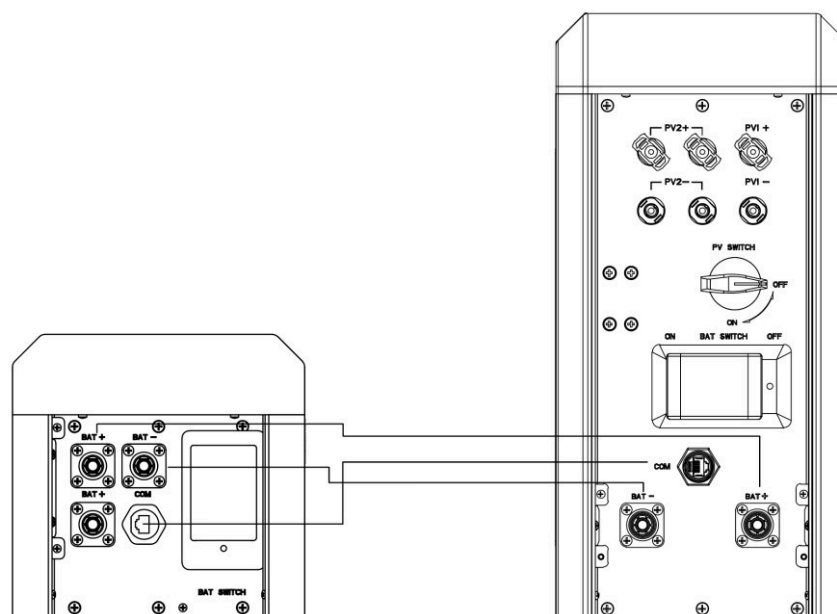

6 Local Configuration

6.1 Local Interface Introduction

Thor Storage Unit has a touch screen on the front of inverter.

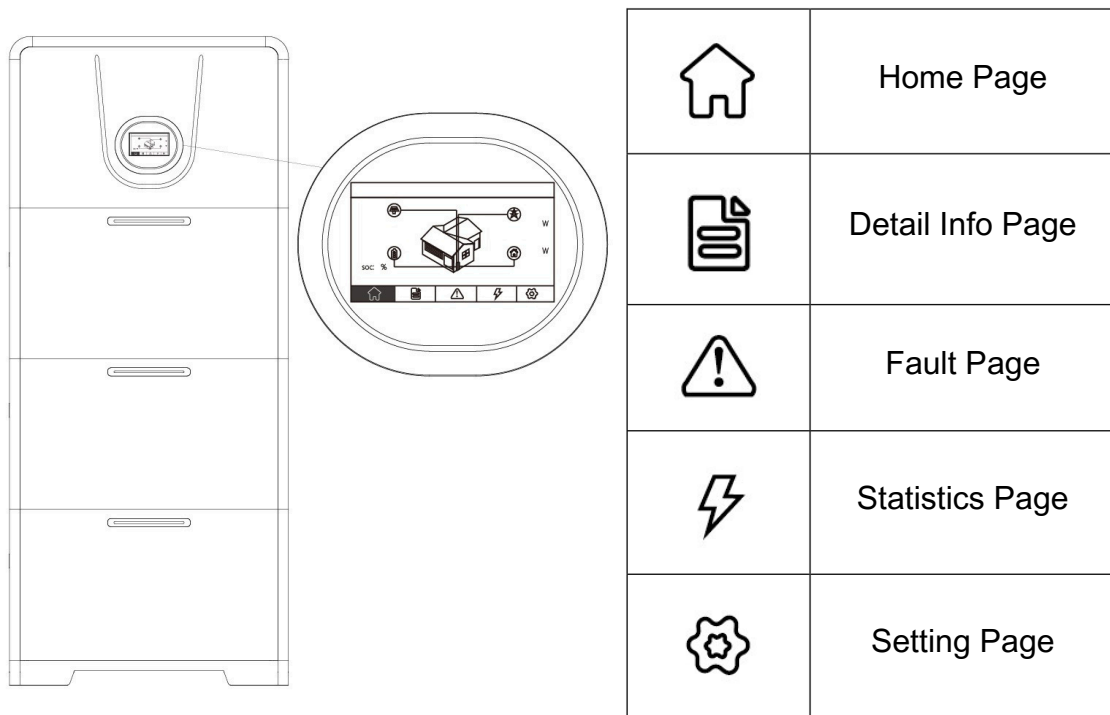

6.2 Home Page

This page shows the total PV input power, AC grid power, battery power and SOC, load power.

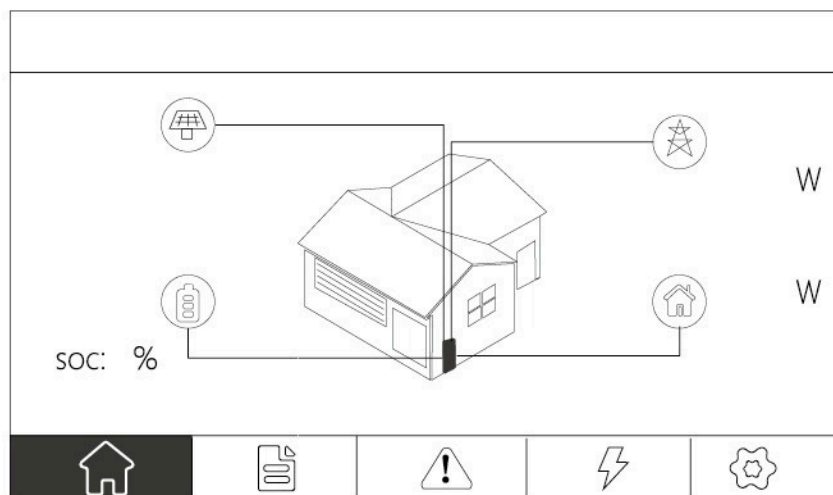

6.3 Detail Info Page

6.3.1 PV Info Page (only Hybrid)

This page shows the voltage, current and power of two different PV inputs.

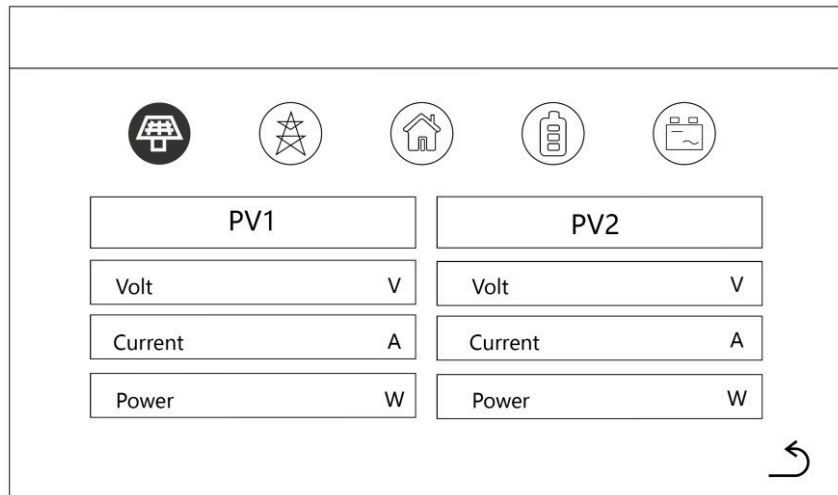

6.3.2 Grid Info Page

This page shows the voltage, current, power and frequency of AC grid.

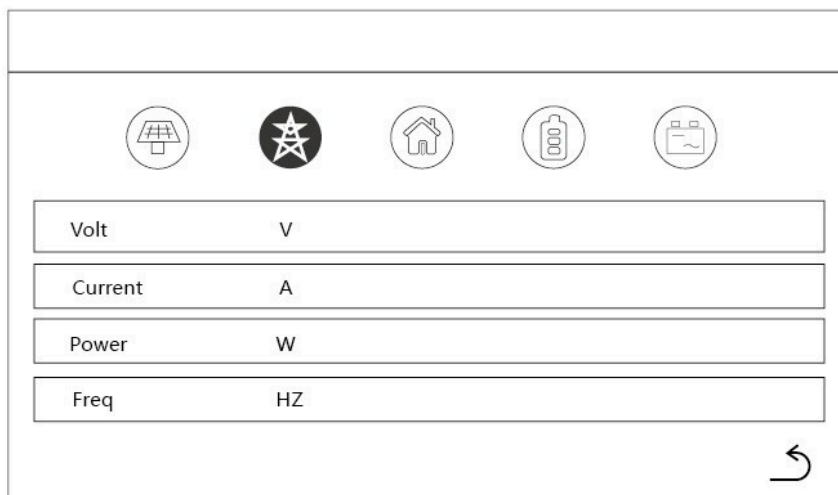

6.3.3 Load Info Page

This page shows the voltage, current and power of the loads.

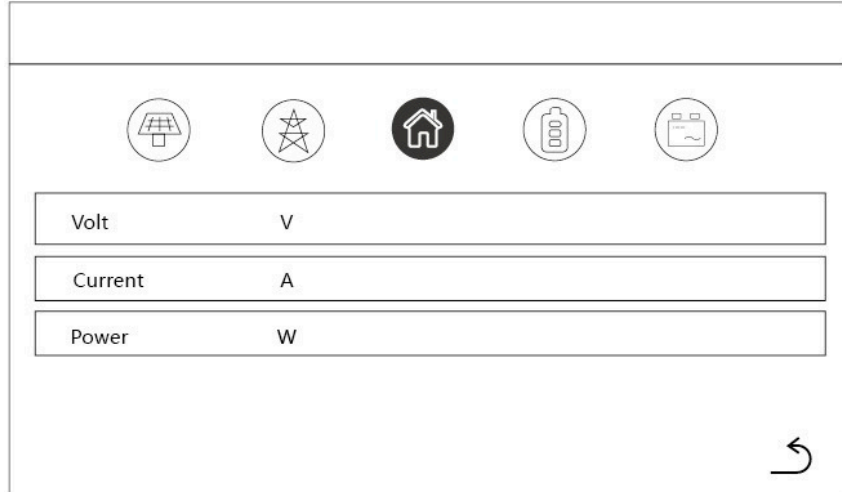

6.3.4 Battery Info Page



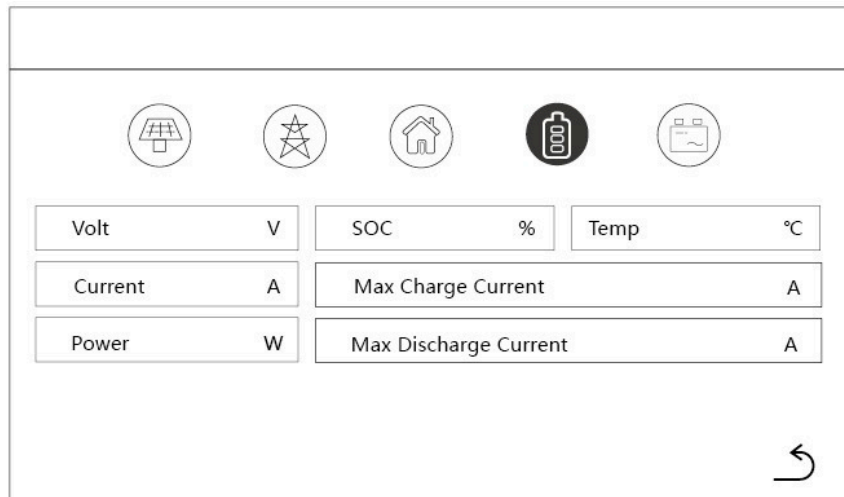

This page shows the voltage, SOC, temperature, current, power and charging/discharging limit of the battery.



Battery LED indication status

6.3.5 Inverter Info Page

This page shows the BUS voltage, internal temperature of the inverter.

    	
S_BUS_Volt	V
N_BUS_Volt	V
DCDC_Temp	°C
Inv_Temp	°C
Env_Temp	°C

6.4 Fault Page

This page shows the real-time fault alarm and fault history of the storage unit.

Real-time Alarm
History

▲

▼



Real-time Alarm
History

▲

▼



6.5 Statistics Page

These two pages show statistics info of Grid, Battery, PV and Load.

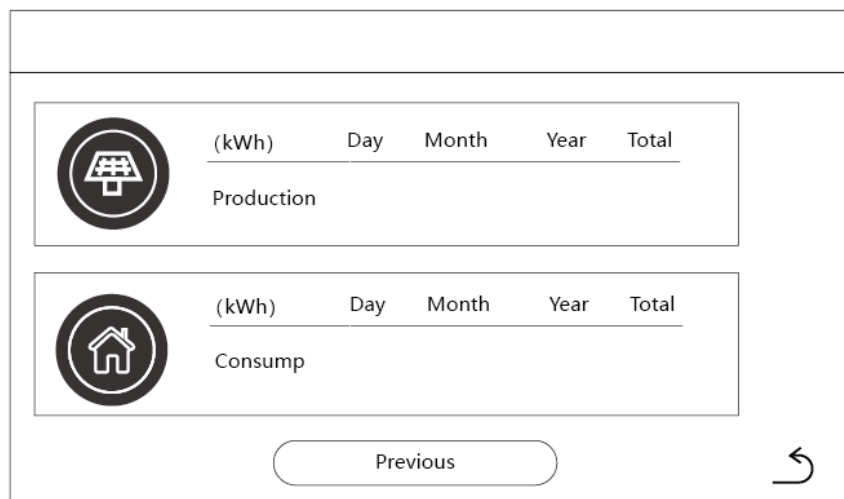
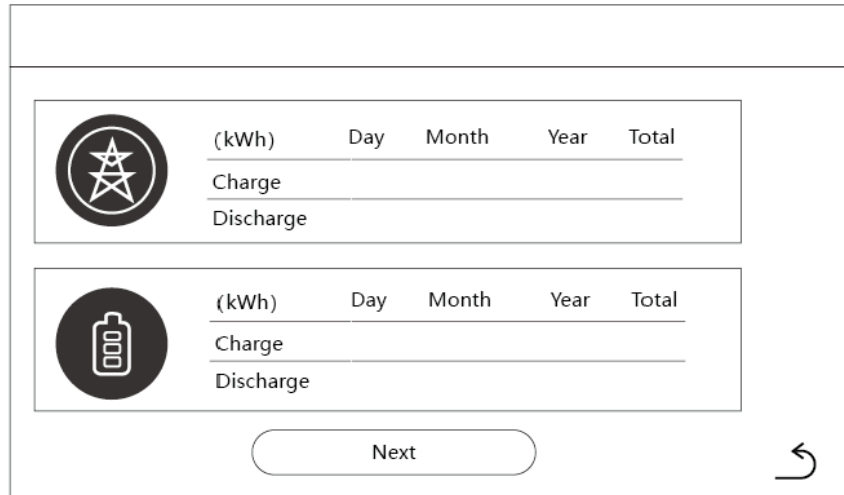

6.6 Setting Page

6.6.1 Brightness Setting Page

This page shows the brightness setting and screen off time setting.

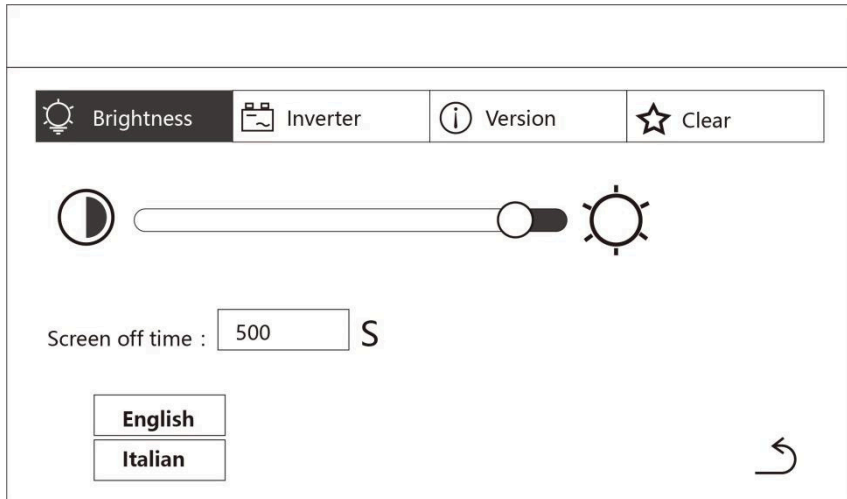

The value range is shown as below:

Item	Description	Range
Brightness	the brightness of screen	Min - Max
Screen off time	the time to turn off the screen	5 – 500 s

6.6.2 Inverter Setting Page

This page needs a password. The default password is “12345”. Installer can change it in this menu.



1) System Setting

This page shows the work mode setting, PV input setting, EPS Enable setting,

battery awoken setting, zero export setting, Arc detection setting, date setting and time setting.

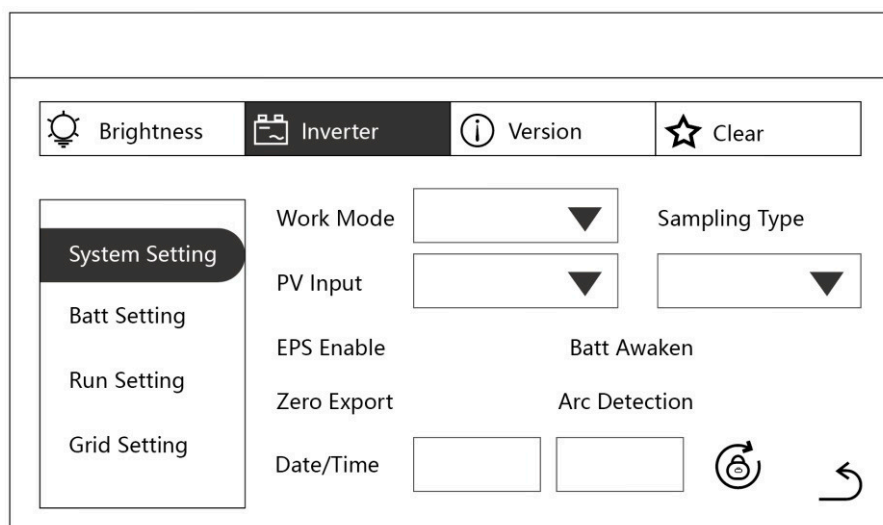

The value range is shown as below:

Item	Description	Default Setting	Range
Work Mode	Work mode of the storage unit	Self Consume	① Self Consume ② Peak Shift ③ Bat Priority
PV Input	PV input mode of the storage unit	Independent	① Independent ② Parallel ③ CV (only factory test)
Sampling Type	CT or Meter Selection	CT	① CT ② Meter-Single ③ Meter-Three
EPS Enable	Turn on/off the EPS output	ON	ON / OFF
Batt Awaken	Wake up the battery in some special time	OFF	ON / OFF
Zero Export	Limit the export power to the public power grid	OFF	ON / OFF
Arc Detection	Turn on/off the Arc detection of PV	OFF	ON / OFF
Date	Date	-	20000101 – 20991231
Time	Time	-	000000 – 235959
Password	Reset the password	12345	10000 - 65535

Note!



- The “CV” mode in the PV Input setting is used for the factory test. Don’t choose it during the installation.
- The “Date” should be set with 8 numbers. First 4 numbers are “year”. Second 2 numbers are “Month”. Last 2 numbers are “Day”. “20000101” means January 1st,2000.
- The “Time” should be set with 6 numbers. First 2 numbers are “hour”. Second 2 numbers are “minute”. Last 2 numbers are “second”. “120101” means 12:01:01.

Self Consume Mode:

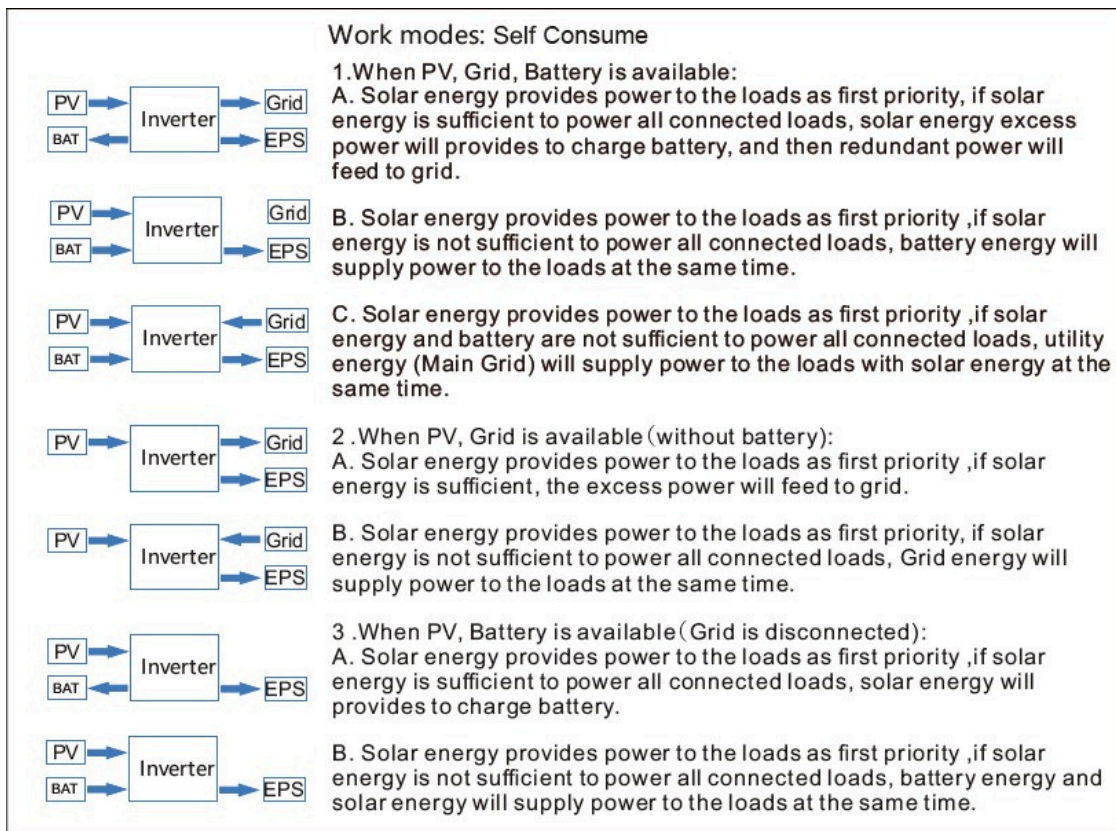

Peak Shift Mode:

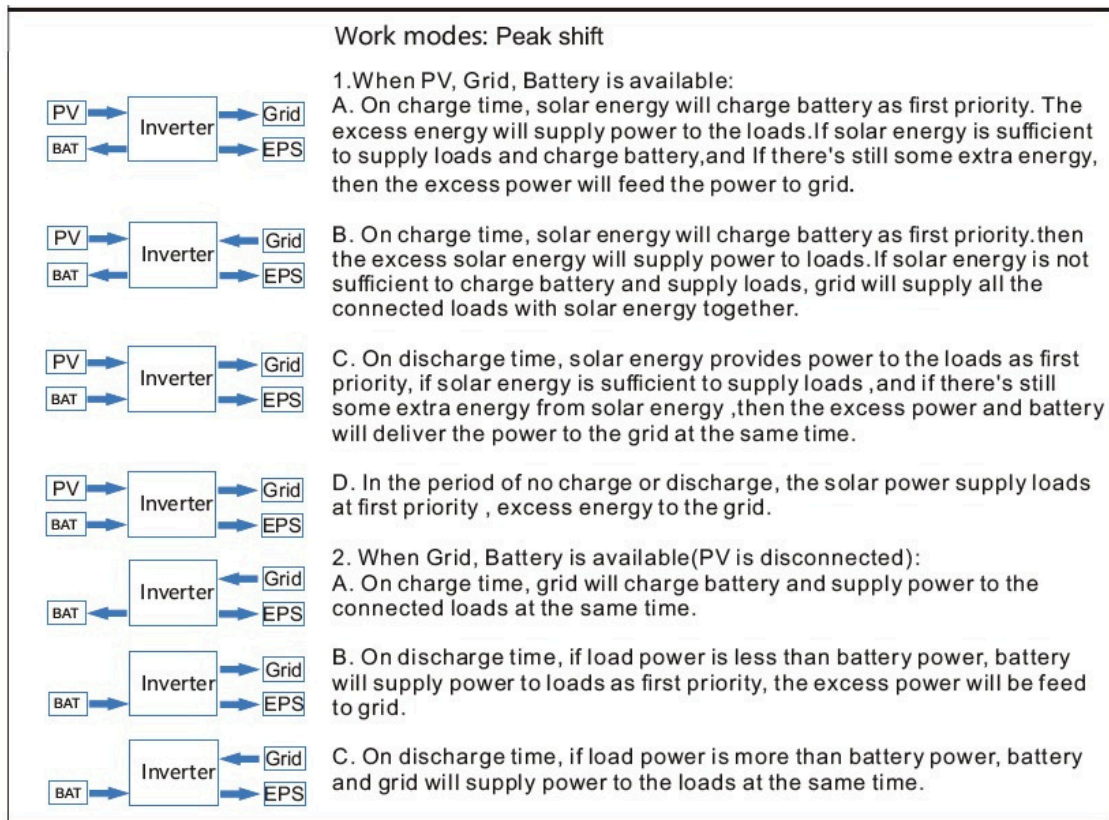

Work mode: Peak Shift

Charge Time 1: Start <input type="text"/> End <input type="text"/>	Disharge Time 1: Start <input type="text"/> End <input type="text"/>
Charge Time 2: Start <input type="text"/> End <input type="text"/>	Disharge Time 2: Start <input type="text"/> End <input type="text"/>
Charge Time 3: Start <input type="text"/> End <input type="text"/>	Disharge Time 3: Start <input type="text"/> End <input type="text"/>

Item	Description	Range
Start	Start time of charge/discharge	0000 – 2359
End	End time of charge/discharge	0000 – 2359



Note !

- The “Start” and “End” should be set with 4 numbers. First 2 numbers are “hour”. Second 2 numbers are “minute”. “1201” means 12:01

Bat Priority Mode:

Work modes: Bat priority

1. When PV, Grid, Battery is available:
A. Solar energy will charge battery as first priority, if solar energy is excess, the excess power will supply load. If there's still some extra energy, then the excess power will feed the power to grid .
B. Solar energy will charge battery as first priority, if solar energy is excess, the excess power will supply load. If solar energy is not sufficient to charge battery and supply loads, grid will supply power to loads.

2. When Grid, Battery is available (PV is disconnected):
Grid will supply power to load and charge battery at the same time.

2) Batt Setting

This page shows the battery type setting, on-grid DOD setting, off-grid DOD setting, charge current setting, Hysteresis setting, battery communication setting and grid rate setting.

Brightness | Inverter | Version | Clear

System Setting
Batt Setting
Run Setting
Grid Setting

Batt Type [Dropdown]
On Grid DOD [Input] | Off Grid DOD [Input]
Charge Curr [Input] | Hysteresis [Input]
Batt-Comm [Dropdown]
Grid-Rate [Dropdown]

↶

The value range is shown as below:

Item	Description	Default Setting	Range
Batt Type	Battery type of the storage unit	Lithium	① DC Source (only factory test) ② Lead-Acid (only service test) ③ Lithium
On-grid DOD	Depth of discharge in the on-grid mode	80	10 - 90
Off-grid DOD	Depth of discharge in the off-grid mode	80	10 - 90
Charge-Curr	Current limit of charge	100	1 - 170
Hysteresis	Hysteresis of the battery DoD	20	10 - 90
Batt-Comm	Battery communication type of the storage unit	CAN	① RS485 ② CAN
Grid-Rate	type of the AC power grid	220V Single	① 220 V Single ② 120V/240V ③ 120V/208V ④ 120V Single

Note!



- The “Batt Type” should be set as “Lithium”. Don’t choose others during the installation.
- The “Batt Comm” should be set as “CAN”. Don’t choose others during the installation.

3) Runing Setting

This page shows the react mode setting, grid power setting, discharge power setting, grid voltage setting, grid frequency setting and grid standard setting.

The screenshot shows a control interface with a top navigation bar containing 'Brightness', 'Inverter', 'Version', and 'Clear'. On the left is a sidebar menu with 'System Setting', 'Batt Setting', 'Run Setting' (highlighted), and 'Grid Setting'. The main area contains the following settings:

- React Mode: [input field]
- Grid Power: [input field] Disc Power: [input field]
- Grid Voltage(V): Low [input field] High [input field]
- Grid Freq(HZ): Low [input field] High [input field]
- Grid Std: [input field]

A refresh icon is located at the bottom right of the settings area.

The value range is shown as below:

Item	Description	Default Setting	Range
React Mode	The react mode of the storage unit	Power Factor	① Power Factor ② React Power ③ Qu Wave ④ Qp Wave
Grid Power	export power to the AC power grid	100	0 - 100
Disc Power	Discharge power of the battery	100	0 - 100
Grid Voltage (Low)	Change the protection setting if it is different from the grid standard	150.0	150.0 – 220.0
Grid Voltage (High)		280.0	240.0 – 280.0
Grid Frequency (Low)		45.00	40.00 – 70.00
Grid Frequency (High)		55.00	40.00 – 70.00
Grid Std	grid standard for different counties	CN	Shown as below

 **Note !**

- The Grid Standard is shown as below and it will keep updating with the certificate testing.

AU	US	ITA
AU-W	THAIL	SLO
NZ	ZA	CZE
UK	custom	SWE
PK	POL	HU
KR	EN50549	SK
PHI	VED4105	AT
CN	JPN	BE



4) About "Autotest"

According to the requirements of the Italian grid standard CEI0-21, inverter needs to have IPS self-inspection function. In the interface for selecting grid standards, click ITA to enter the Autotest interface.

	59.S2(V)	27.S2(V)	81 > S2(Hz)	81 < S2(Hz)	
Autotest	<input type="text"/>	<input type="text"/>	<input type="text"/>	<input type="text"/>	
T(ms)	<input type="text"/>	<input type="text"/>	<input type="text"/>	<input type="text"/>	
Trip.V/Hz	<input type="text"/>	<input type="text"/>	<input type="text"/>	<input type="text"/>	Start
Current.V/Hz	<input type="text"/>	<input type="text"/>	<input type="text"/>	<input type="text"/>	
Test.T(ms)	<input type="text"/>	<input type="text"/>	<input type="text"/>	<input type="text"/>	
Pass/Fail	<input type="text"/>	<input type="text"/>	<input type="text"/>	<input type="text"/>	
	Test1	Test2			

	59.S2(V)	27.S2(V)	81 > S2(Hz)	81 < S2(Hz)	
Autotest	<input type="text"/>	<input type="text"/>	<input type="text"/>	<input type="text"/>	
T(ms)	<input type="text"/>	<input type="text"/>	<input type="text"/>	<input type="text"/>	
Trip.V/Hz	<input type="text"/>	<input type="text"/>	<input type="text"/>	<input type="text"/>	
Current.V/Hz	<input type="text"/>	<input type="text"/>	<input type="text"/>	<input type="text"/>	
Test.T(ms)	<input type="text"/>	<input type="text"/>	<input type="text"/>	<input type="text"/>	
Pass/Fail	<input type="text"/>	<input type="text"/>	<input type="text"/>	<input type="text"/>	
	Test1	Test2			

Click "Start" to enter the test interface below. Note that the test can only begin when the power grid is connected.

	59.S2(V)	27.S2(V)	81 > S2(Hz)	81 < S2(Hz)	
Autotest	<div style="text-align: center;"> Testing..... About wait 5 minutes.</div>				
T(ms)					
Trip.V/Hz					Start
Current.V/Hz					
Test.T(ms)					
Pass/Fail					<input type="text" value="Wait"/>
	Test1	Test2			

After waiting for 5 minutes, the following interface is displayed

	59.S2(V)	27.S2(V)	81 > S2(Hz)	81 < S2(Hz)	
Autotest	<input type="text"/>	<input type="text"/>	<input type="text"/>	<input type="text"/>	Start
T(ms)	<input type="text"/>	<input type="text"/>	<input type="text"/>	<input type="text"/>	
Trip.V/Hz	<input type="text"/>	<input type="text"/>	<input type="text"/>	<input type="text"/>	
Current.V/Hz	<input type="text"/>	<input type="text"/>	<input type="text"/>	<input type="text"/>	
Test.T(ms)	<input type="text"/>	<input type="text"/>	<input type="text"/>	<input type="text"/>	
Pass/Fail	<input type="text"/>	<input type="text"/>	<input type="text"/>	<input type="text"/>	
	<input type="button" value="Test1"/>	<input type="button" value="Test2"/>		<input type="button" value="↶"/>	

	59.S2(V)	27.S2(V)	81 > S2(Hz)	81 < S2(Hz)	
Autotest	<input type="text"/>	<input type="text"/>	<input type="text"/>	<input type="text"/>	Start
T(ms)	<input type="text"/>	<input type="text"/>	<input type="text"/>	<input type="text"/>	
Trip.V/Hz	<input type="text"/>	<input type="text"/>	<input type="text"/>	<input type="text"/>	
Current.V/Hz	<input type="text"/>	<input type="text"/>	<input type="text"/>	<input type="text"/>	
Test.T(ms)	<input type="text"/>	<input type="text"/>	<input type="text"/>	<input type="text"/>	
Pass/Fail	<input type="text"/>	<input type="text"/>	<input type="text"/>	<input type="text"/>	
	<input type="button" value="Test1"/>	<input type="button" value="Test2"/>		<input type="button" value="↶"/>	

Test1, Test2, the interface shows the PASS data represents the test passed.

5) Grid Setting

This page shows the voltage reset setting, frequency reset setting, leak current setting, active island setting and insulation detection setting.

<input type="button" value="Brightness"/> <input checked="" type="button" value="Inverter"/> <input type="button" value="Version"/> <input type="button" value="Clear"/>		
System Setting Batt Setting Run Setting Grid Setting	PWR Volt Res	Leak Curent
	PWR Freq Res	Active Island
	PFC Volt Res	
	PFC Freq Res	
	Insulation Detection	
		<input type="button" value="↶"/>

Item	Description	Default Setting	Range
PWR-Volt Res	Turn on/off the protect setting	ON	ON / OFF
PWR-Freq Res		ON	ON / OFF
PFC-Volt Res		ON	ON / OFF
PFC-Freq Res		ON	ON / OFF
Leak Current		ON	ON / OFF
Active Island		ON	ON / OFF
Insulation Detection		ON	ON / OFF

6.6.3 Version Page

This page shows the version and serial number of the storage unit.

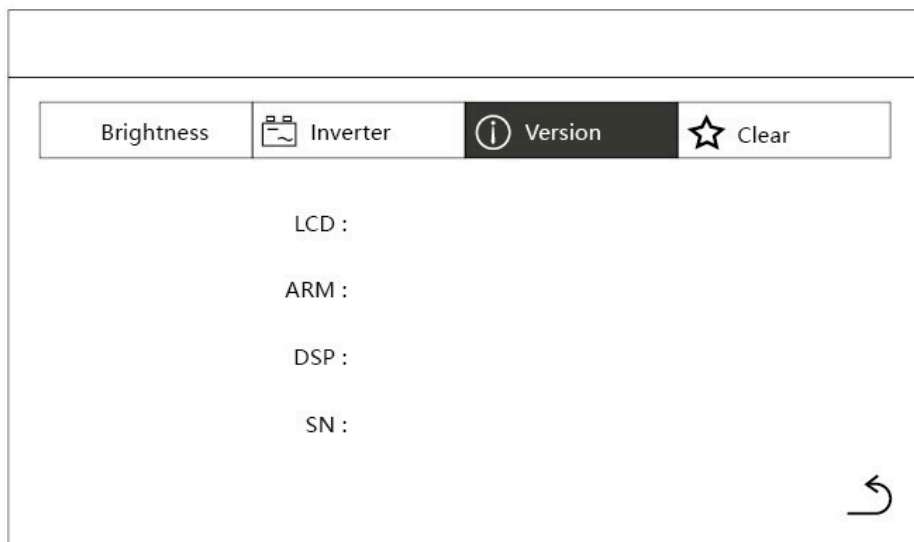

6.6.4 Clear Page

This page needs a password. The default password is “12345”. Installer can change it in the inverter setting.

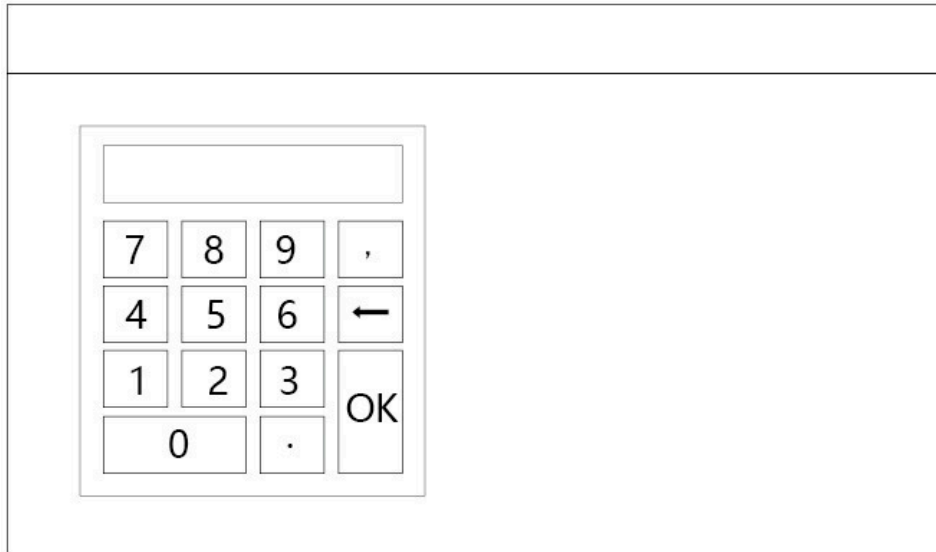

This page shows the clear options of the storage.

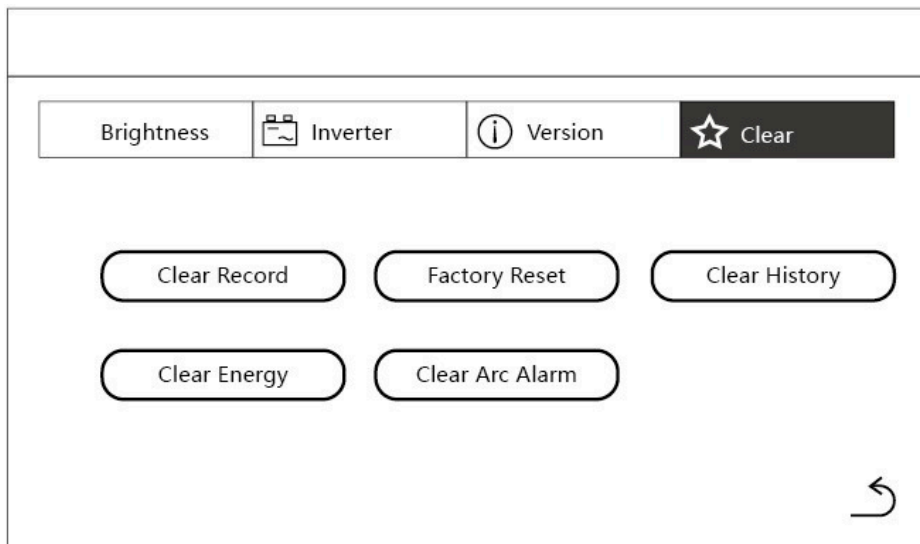

Note !



- All the data can not be restored after the clearance!

6.7 Start up the System

The system shall be turned ON in the correct sequence as follows:

- 1) Turn ON the BAT switch at the right side of the inverter.
- 2) Press power button at the right side of the batteries to turn on batteries, the order should be Battery No.4> Battery No.3> Battery No.2> Battery No.1; Observe the status light on the front of the battery.

- 3) Wait for 30s and observe the LCD on the front of inverter to check the running status.
- 4) Turn ON the PV switch at the left side of the inverter.
- 5) Turn on external AC switch.
- 6) If the system is running normal, please do commission configuration. If the system is not work normally, please re-check the wiring and setting until the system runs normal.
- 7) Set the details on the local screen.

Note !



- The start-up procedure for the system should be: Inverter BAT switch >> Battery No. 4>> Battery No. 3>> Battery No.2>> Battery No.1 >>Inverter PV switch (PV not powered) >> External AC switch.

6.8 Shut Down the System

System shall be turned OFF in the correct sequence as follows:

- 1) Turn off the external grid AC switch.
- 2) Turn off the PV switch at the left side of the inverter.
- 3) Press the POWER button on the right side of the battery. the order should be Battery No.4> Battery No.3> Battery No.2> Battery No.1;
- 4) Turn OFF the Battery switch on the right side of the inverter.

Note !



- The procedure for turning off the system will be External AC switch >> Inverter PV switch (only Hybrid) >> Battery No.4>> Battery No.3>> Battery No.2>> Battery No.1>> Inverter BAT switch.

6.9 LED indication

6.9.1 Bat LED

LED status

Battery Status	Protection, alarm normal	RUN	ALM	Description
		Green	Red	/
Off	/	Off	Off	All off
On	Normal	Flash 1	Off	No charging or discharging
	Warning	Flash 1	Flash 3	PACK low voltage
Charge	Normal	ON	Off	/
	Warning	ON	Flash 3	/
	Over Charge	On	Off	Stop charging
	Over Temp/Current,Failure	Off	On	
Discharge	Normal	Flash 3	Off	/
	Warning	Flash 3	Flash 3	/
	Over Discharge	Off	Off	Stop discharging
	Over Temp/Current,Failure	Off	On	
Failure	/	Off	On	Stop charging and discharging

Flash description:

Flash 1: 0.25s on/3.75s off

Flash 2: 0.5s on /0.5s off

Flash 3: 0.5s on,1.5s off

6.9.2 System status indicator

Work Mode	Status
Alarm or Fault	Red light keeps on
Normal	Green light slow flashing
Power off	Light off
BAT Low capacity/ Bat Under	Yellow light slow flashing
Communication failure	White light keeps on
Standby	Light off

7 Fault Codes and Common troubleshooting

Content	Codes	Explanation	Solution
Over Discharge Current	001	1, If work in the off-grid mode, the load is higher than inverter power. 2, The discharge current limit is too low. 3, If install only one battery, the inverter power is higher than 5kW.	1, If work in the off-grid mode, check the off-grid load and make sure it is lower than the inverter output power. 2, Check the discharge current limit and set a higher value. 3, If install only one battery, try to install more batteries. 4, If the problem still exists, contact manufacturer.
Over Load	002	If work in the off-grid mode, the load is too high.	1, If work in the off-grid mode, check the off-grid load and make sure it is lower than the inverter output power and battery power. 2, If the load is inductive load, wait for several minutes and check if the problem still exists. 3, If the problem still exists, contact manufacturer.
Batt. Disconnected	003	1, Battery switch is turned off. 2, Battery button is turned off. 3, Battery cables are disconnected. 4, Battery fuse is disconnected.	1, Check the battery switch and turn on it. 2, Check the battery button and turn on it. 3, Check the battery cables. 4, Check the battery fuse. 5, If the problem still exists, contact manufacturer.
Batt. Under Capacity	004	Battery capacity is low and the battery voltage is low.	1, Charge the battery and keep the capacity higher than 20%. 2, If the problem still exists, contact manufacturer.
Batt. Low Capacity	005	Battery capacity is low.	1, Charge the battery and keep the capacity higher than (SOC>100%-DOD+ Hysteresis). 2, If the problem still exists, contact manufacturer.
batt. High Volt	006	1, Battery is damaged. 2, Battery sampling is damaged.	1, Measure the voltage and check if it is normal. 2, If the problem still exists, contact manufacturer.
Grid Low Volt	007	Grid voltage is abnormal.	1, Check if the power grid is normal. 2, Check if the country is set correctly 3, Check if the voltage range is set correctly 4, If the problem still exists, contact manufacturer.
Grid High Volt	008		
Grid Low Freq.	009	Grid Frequency is abnormal.	1, Check if the power grid is normal. 2, Check if the country is set correctly 3, Check if the frequency range is set correctly 4, If the problem still exists, contact manufacturer.
Grid High Freq.	010		
BUS Low Volt	014	BUS voltage is lower than normal.	Restart the system. If the problem still exists, contact manufacturer.
BUS High Volt	015	BUS voltage is over maximum value.	1, Check if the PV input voltage is higher than limit. 2, Check if the battery is too high 3, Restart the system. If the problem still exists, contact manufacturer.
Inv. Over Current	016	1, If work in the off-grid mode, the load is too high. 2, If work in the off-grid mode, the RCD load is too high. (For example, air-conditioning)	1, Check the load and make sure it is lower than the inverter output power. 2, Restart the system. If the problem still exists, contact manufacturer.

Content	Codes	Explanation	Solution
Over Charge Current	017	1, The battery charge limit is too high. 2, If install only one battery, the inverter charge power is higher than 5kW.	1, Check if the inverter charge limit is set correctly. 2, If install only one battery, try to install more batteries. 3, If the problem still exists, contact manufacturer.
Inv. Under Volt	019	INV voltage is abnormal.	If the problem still exists, contact manufacturer.
Inv. Over Volt	020		
Inv. Abnormality Freq.	021	INV frequency is abnormal.	If the problem still exists, contact manufacturer.
IGBT High Temp.	022	Bad heat dissipation of inverter.	1, Check the installation position and keep a good heat dissipation of inverter. 2, If the problem still exists, contact manufacturer.
Batt. Over Temp.	024	1, Bad heat dissipation of battery. 2, Battery keeps discharge within a high power.	1, Check the installation position and keep a good heat dissipation of battery. 2, If in the Peak Shift mode, change a shorter discharge time. 3, If in the Self Consume mode, install more batteries. 4, If the problem still exists, contact manufacturer.
Batt. Under Temp.	025	Battery temperature is lower than the allowed value.	1, Check if the environment temperature is too low. 2, Use small load first until the warning disappear. 3, If the problem still exists, contact manufacturer.
BMS Comm. Fail	028	1, Battery communication cable is damaged, 2, Battery address is set incorrectly. 3, Battery button is turned off.	1, Check if the battery button is turned on. 2, Check if the battery communication cable is normal. 3, Check if the battery address is set correctly. 4, If the problem still exists, contact manufacturer.
Fan Fail	029	Fan fail.	1, If the problem still exists, contact manufacturer.
Grid Over Load	030	The bypass load in the grid side is too high.	1, Check if the off-grid load is too high. 2, If the problem still exists, contact manufacturer.
BUS Soft Start Fail	033	The inverter may be damaged.	1, Restart the system. If the problem still exists, contact manufacturer.
Inv. Soft Start Fail	034		
BUS Short Circuit	035		
Inv. Short Circuit	036		
Fan Locked Fail	037	Fan fault.	1, If the problem still exists, contact manufacturer.
PV Insulation Low	038	PV Low insulation impedance.	1, Check if the PV cable is damaged. 2, When it is raining, keep observing and check if the problem still exists when it is sunny. 3, If the problem still exists when it is sunny, contact manufacturer.

Content	Codes	Explanation	Solution
BUS Relay Fault	039	The inverter may be damaged.	1, Restart the system. If the problem still exists, contact manufacturer.
Grid Relay Fault	040		
EPS Relay Fault	041		
GFCI Fault	042		
PV Input Short Circuit	044		
Bypass Relay Fault	045		
System Fault	046		
Inv. Current DC Over	047		
Inv. Volt DC Over	048		
Device Comm. Fail	049	The indicator board fails to communicate with the display	1. Restart. 2. Contact us

8 Battery Maintenance

8.1 Transportation

Lithium batteries are dangerous goods. Passed the test of UN38.3, this product meets the transportation requirements for dangerous goods for lithium batteries. After the installation of the battery on site, the original packaging (contains the lithium battery identification) should be kept. When the battery needs to be returned to the factory for repair, please pack the battery with the original packaging to reduce unnecessary trouble.

8.2 Storage

After purchasing the battery, please store it with following instructions:

- 1) Please store it in a dry and ventilated environment, keep it away from heat sources.
- 2) Please keep it in an environment with storage temperature as $-20^{\circ}\text{C} \sim 50^{\circ}\text{C}$, humidity $<85\%$ RH.
- 3) For long-term storage (>3 months), please put it in an environment with a temperature of 18°C to 28°C and a humidity of $<85\%$ RH.
- 4) The battery should be stored in accordance with the storage requirements mentioned above, and the battery should be installed within 6 months since delivered from the factory and used with compatible inverters.



Note !

- The battery remains 30% power when it is sent from the factory.
- The longer the battery is stored, the DOD value is getting bigger. When the battery remaining voltage fails to reach the startup voltage requirement, the battery may be damaged.

The battery cannot be disposed of as household refuse. When the service life of the battery reaches to the limit, it is not required to return it to the dealer or Thor, but it must be recycled to the special waste lithium battery recycling station in the area.

8.3 Cleanliness

Clean the enclosure lid, LCD of the inverter with moistened cloth with clear water only. Do not use any cleaning agents as it may damage the components.